

# INNOVATIVE 2023



17 The Boulevard  
Te Rapa, Hamilton  
New Zealand

Ph: 07 849 3514  
Email: office@abe.co.nz  
Web: www.abe.co.nz



Pg. 29 :: Painters Prep Cart  
with Masker

## NEW SuperStand 6

Pg. 15



Pg. 1 :: Parts Cart B™

U.S. :: 1-866-438-4884    DIRECT :: 1-651-415-0733

FOR MORE INFORMATION, CONTACT YOUR LOCAL JOBBER OR FIND ONE ONLINE BY VISITING

[WWW.INNOVATIVETOOLS.COM](http://WWW.INNOVATIVETOOLS.COM)



**INNOVATIVE**  
TOOLS & TECHNOLOGIES, INC.



## INNOVATIVE TOOLS

Founded in 1996 in St. Paul, Minnesota, by a 21-year auto body technician, Innovative Tools & Technologies knows the needs and problems of body shops, owners and techs first-hand.

Innovative creates and manufactures the best designed, highest quality parts and material management systems for the automotive repair market worldwide. Its products are designed to save space and steps, minimize clutter, enhance efficiency, make processes leaner, and increase profitability.

The company has numerous patents and patents pending. More than 500,000 Innovative products are in use throughout North America, Canada, South America, Europe, Denmark, Finland, Sweden, Switzerland, Japan, South Korea, Australia, and New Zealand.

INNOVATIVE PRODUCTS ARE OFTEN COPIED,  
BUT NEVER DUPLICATED.

# HIGHEST QUALITY. GUARANTEED.

## Product Index

Parts Carts . . . . .	1-8
Paint Stands. . . . .	9-19
Spray Gun Holders. . . . .	20
Spray Gun Cabinets. . . . .	21
Estimating Cart . . . . .	22-23
UV Light. . . . .	24
Color Match Lights. . . . .	25-28
Material Carts . . . . .	29-33
Glass Storage. . . . .	34
Panel Storage. . . . .	35
Bumper Storage. . . . .	36
Large Part Handling. . . . .	37-40
Maskers & Dispensers . . . .	41-44
X-Stand . . . . .	45-46

### Innovative Parts Cart B™ PART # SSPC-B

U.S. PATENT 7,314,143, 7,708,156,  
OTHER PATENT PENDING



> *When nested, each cart only takes 8" of additional floor space*



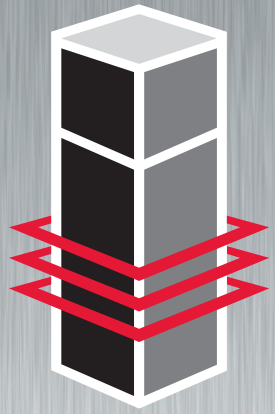

**INNOVATIVE**

**TOOLS & TECHNOLOGIES, INC.**

2016 GATEWAY CIRCLE

ST. PAUL, MINNESOTA 55038-7783

**HIGHEST QUALITY  
EQUIPMENT MADE**





All A, B & C Series Parts Carts come standard with telescoping support arms



> Patented High-carbon, heat-treated steel shelf brackets for a lifetime of trouble free use



> 4" Total-lock wheels provide a unique braking system triggered by the touch of a toe



> 2 Telescoping Support arms 18" to 27" range



Weight rating: 125 lbs. per shelf for all Parts Carts

**Innovative Parts Cart B™**  
**PART # SSPC-B**

U.S. PATENT 7,314,143 7,708,156  
OTHER PATENT PENDING

**Includes:**

- > 3 Standard shelves
- > 2 Telescoping Support arms 18" to 27" range
- > 6 Storage hooks
- > 2 Bungee cords

**Benefits:**

- > Proven to reduce cycle time
- > Vertical storage saves valuable floor space
- > Open design for easy loading & unloading
- > Load parts directly from the delivery truck
- > Less handling of parts means less risk of damage
- > With a designated Parts Cart for each job, any unused parts can be returned for full credit

**Features:**

- > 30% more shelf positions than any other parts carts
- > Patented High-carbon, heat-treated steel shelf brackets for years of trouble-free use
- > Shelves have upper side rails to prevent parts slide-off
- > 4" industrial grade total-lock caster wheels for mobility; zero movement when locked
- > Patented shelf brackets adjust in seconds to accommodate larger parts
- > Holds 125 lbs. per shelf
- > When nested, each cart only takes 8" of additional floor space
- > Durable powder coat finish
- > Only parts cart with a Lifetime warranty

1 Visit our website and compare for yourself what separates an **Innovative Parts Cart** from cheap imitations



# THE HIGHEST QUALITY PARTS CARTS MADE. BACKED BY A LIFETIME WARRANTY.



> Deep Basket with flip-down front for easy loading and unloading

**Innovative Parts Cart B™  
with Deep Basket**  
**Part # SSPC-B/DB**

U.S. PATENT 7,314,143, 7,708,156,  
OTHER PATENT PENDING

**Includes:**

- > 2 Standard shelves
- > 1 Deep Basket
- > 2 Telescoping Support arms  
18" to 27" range
- > 6 Storage hooks
- > 2 Bungee cords



**Innovative Parts Cart A™**  
**Part # SSPC-A**

U.S. PATENT 7,314,143, 7,708,156,  
OTHER PATENT PENDING

**Includes:**

- > 2 Standard shelves
- > 2 Telescoping Support arms  
18" to 27" range
- > 6 Storage hooks
- > 2 Bungee cords



**Innovative Parts Cart C™**  
**Part # SSPC-C**

U.S. PATENT 7,314,143, 7,708,156,  
OTHER PATENT PENDING

**Includes:**

- > 6 Standard shelves
- > 2 Telescoping Support arms  
18" to 27" range
- > 2 Support arms (18")
- > 6 Storage hooks
- > 2 Bungee cords



# PARTS CARTS ACCESSORIES

## Innovative Shelf Mat™

### Part # SSPC-SM

- > Durable, easy-to-clean, chemical-resistant work surface
- > Quickly installs onto any Innovative Parts Cart shelf
- > Water-jet cut for exact fit every time



## Innovative Protective Mat™

### Part # SSPC-PM

- > Form-fitted rubber mat covers entire shelf; provides protection for painted or delicate parts
- > Completely eliminates metal-on-metal contact
- > Ideal for aluminum part storage



## Innovative Parts Cart B™ Fully Loaded

### Part # SSPC-B/FL

Cart shown includes the following options:

- > SSPC-B/DB Parts Cart B w/Deep Basket
- > SSPC-PT Panel Train
- > SSPC-HT Hardware Tray
- > SSPC-PP Parts Pan
- > SSPC-MH Molding Holder
- > SSPC-RO RO Holder





# BE PARTS SMART, CUSTOMIZE YOUR CART

## Innovative Panel Train™

### Part # **SSPC-PT**

- > Stores and protects up to three large panels
- > Extensive rubber and foam padding – no metal-on-metal contact; no damage
- > Industry's only convenient post-storage holder
- > Nine post settings for multiple adjustments
- > Can be easily added to Innovative Parts Carts A or B
- > Folds up and stays up for compact, stable storage
- > Durable powder-coat finish resists damage

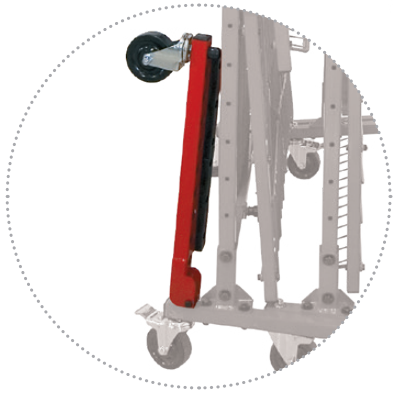

> Folds up and stays up for compact, stable storage

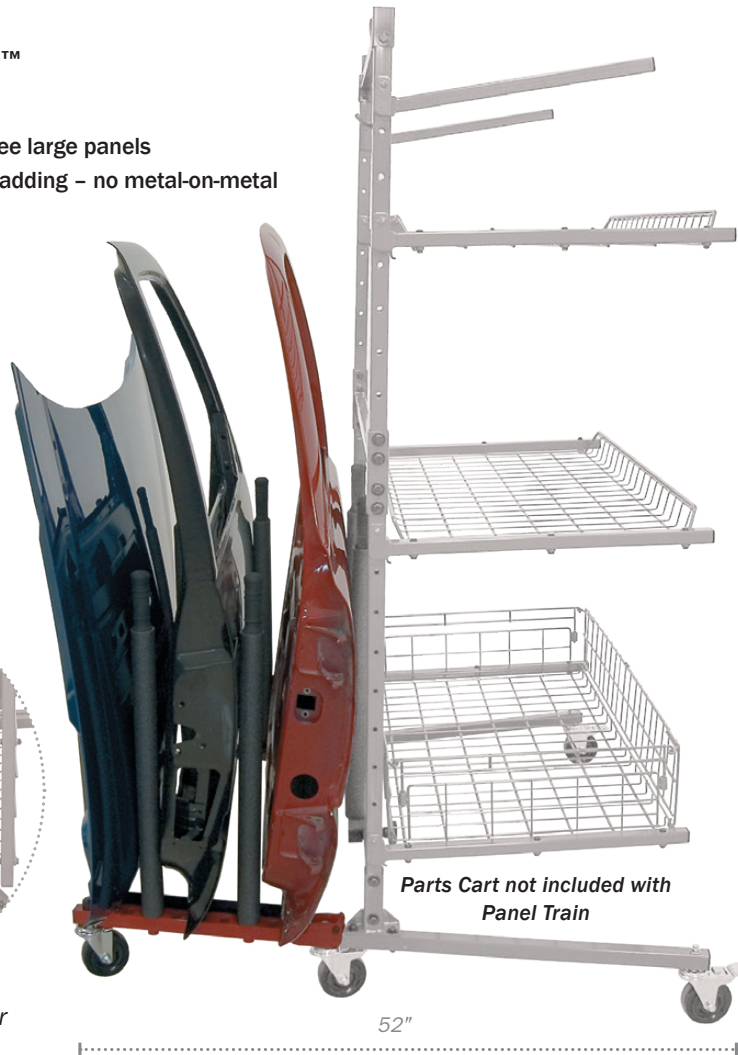

## Telescoping Support arms set

18 to 27 inch range

### Part # **SSPC-BAS-EXT**

For holding bumper covers



## Hook Set (set of 6 hooks)

### Part # **SSPC-HS**

Fits SSPC-A, SSPC-B, and SSPC-C only



## Innovative Hanger Bracket™

### Part # **SSPC-HBK**

- > Convenient, three-hook bracket for hanging padded parts bags and light parts
- > Quickly installs onto any Innovative Parts Cart
- > Durable powder-coat finish

# PARTS CART D SERIES



## Innovative Tools' Most Cost Effective Parts Cart

backed by our *Lifetime Warranty*



### Features:

- > Shelves have upper one inch side rails to prevent parts from sliding off
- > Holds 125 lbs. per shelf
- > Six storage hooks allow you to hang large parts on the sides as shown above
- > Durable powder coat finish
- > Lifetime Warranty

### Innovative Parts Cart D™

#### Part # **SSPC-D**

U.S. PATENT D 871,117

#### Includes

- > 3 standard fixed shelves 24" x 37"
- > 6 storage hooks
- > Four 4" industrial caster wheels
  - 2 - total lock - zero movement when locked
  - 2 - non-locking

### Benefits:

- > Proven to reduce cycle time
- > Vertical storage saves valuable floor space
- > Open design for easy loading & unloading
- > Load parts directly from the delivery truck
- > Less handling of parts means less risk of damage
- > With a designated Parts Cart for each job, any unused parts can be returned for full credit





# PARTS CART D SERIES ACCESSORIES

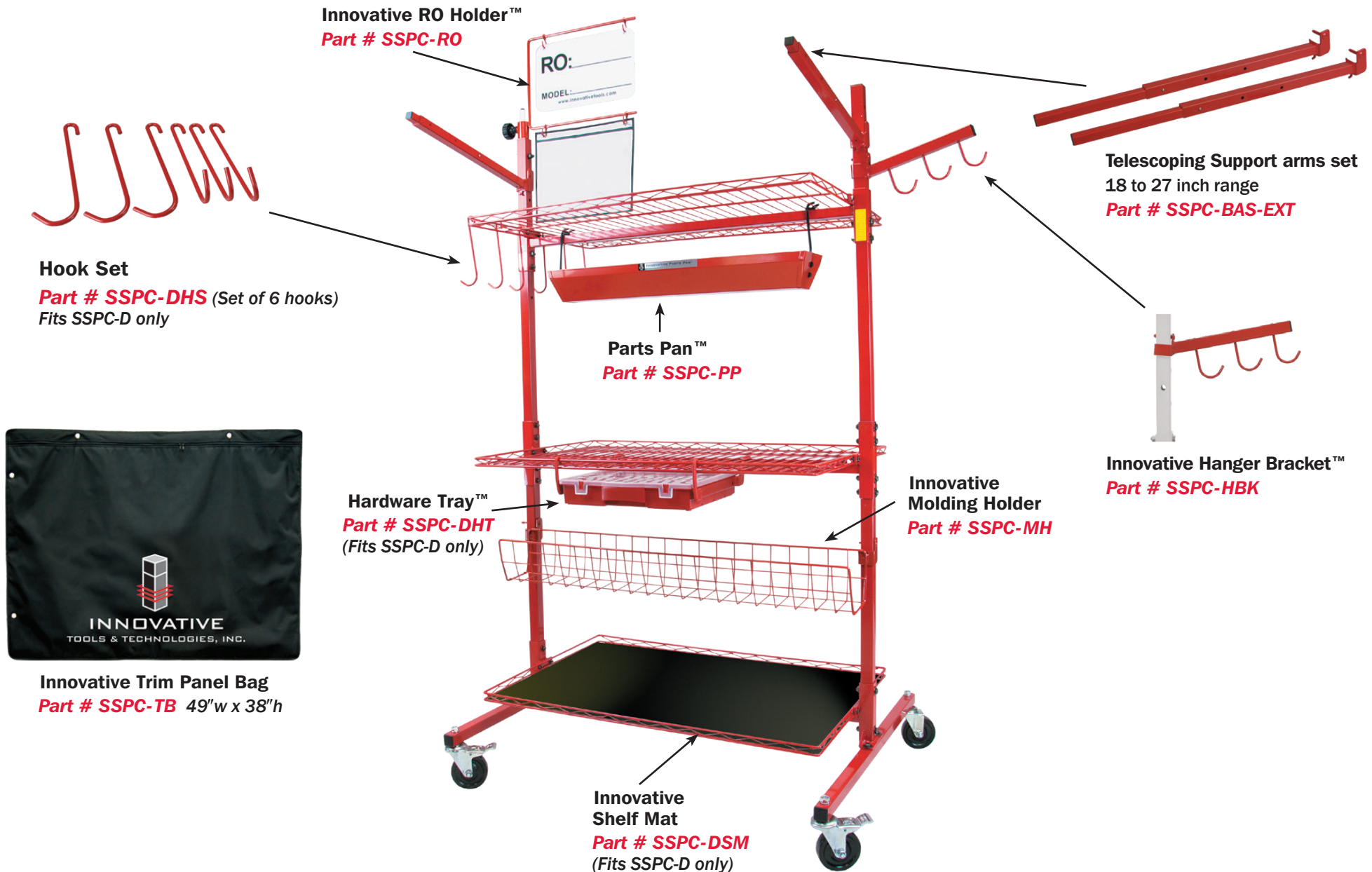

**Innovative RO Holder™**  
**Part # SSPC-RO**



**Hook Set**  
**Part # SSPC-DHS** (Set of 6 hooks)  
Fits SSPC-D only



**Innovative Trim Panel Bag**  
**Part # SSPC-TB** 49" w x 38" h

**Hardware Tray™**  
**Part # SSPC-DHT**  
(Fits SSPC-D only)

**Parts Pan™**  
**Part # SSPC-PP**

**Innovative Molding Holder**  
**Part # SSPC-MH**

**Innovative Shelf Mat**  
**Part # SSPC-DSM**  
(Fits SSPC-D only)

**Telescoping Support arms set**  
18 to 27 inch range  
**Part # SSPC-BAS-EXT**

**Innovative Hanger Bracket™**  
**Part # SSPC-HBK**

# THE KEYS TO BLUEPRINTING

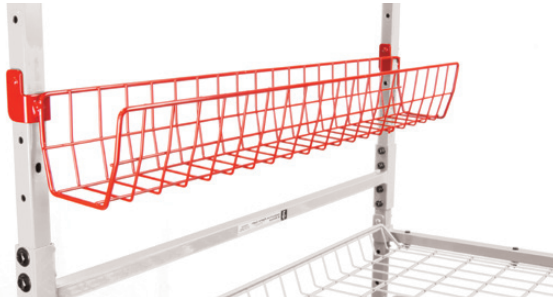

## Innovative Molding Holder™

**Part # SSPC-MH**

The latest option for the entire line of Innovative Parts Carts

- > Keeps long side moldings straight and damage-free
- > Conveniently stores anywhere on the carts, front or back
- > Adjusts in seconds
- > 6"W x 5"D x 42"H
- > Durable powder-coat finish
- > Lifetime warranty



## Innovative Parts Pan™

**Part # SSPC-PP**

- > Organizes & prevents loss or damage of smaller parts
- > Conveniently stores underneath any Innovative Parts Cart shelf
- > Easily removed with a quick "slide & pull"
- > Durable powder-coat finish



## Innovative RO Holder™

**Part # SSPC-RO**

- > Acrylic dry-erase board clearly identifies and tracks each job
- > Clear, two-pocket envelope organizes paperwork and keeps it with the job
- > Quickly mounts to the top of any Innovative Parts Cart
- > Rotates 360 degrees for maximum visibility
- > Dry-erase marker conveniently stores in the RO Holder post



# STOP LOSING HARDWARE

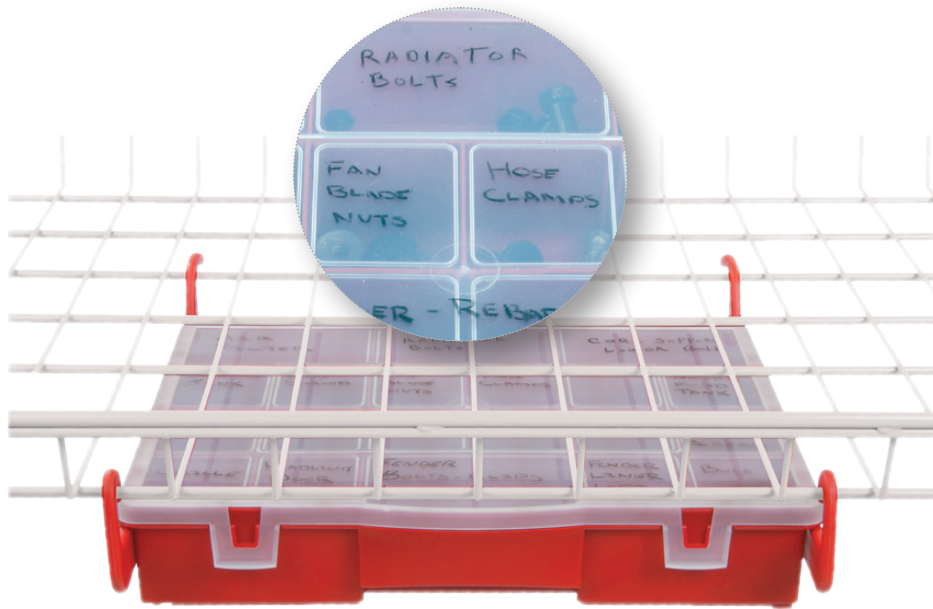

## Innovative Hardware Tray™

**Part # SSPC-HT**

- > Organizes & prevents loss of small nuts, bolts, screws and clips, etc.
- > Conveniently stores underneath any Innovative Parts Cart shelf
- > Easily removed with a quick “lift & pull”
- > Speeds up reassembly time
- > Comes with a grease pencil to mark the clear lid
- > Wet erase marker can also be used
- > Fits SSPC-A, SSPC-B and SSPC-C only

# PROTECT EXPENSIVE HEADLIGHTS AND TRIM PANELS



**Trim Panel Bag**

**Part # SPC-TB**

## Innovative Padded Parts Bag™

Padded protection for expensive parts

- > Heavy-duty nylon exterior, soft padded nylon interior
- > Protects delicate and expensive parts from dust and damage
- > Industrial grommets allow bags to hang from Parts Carts
- > Parts can now be stored in the vehicle, without damaging the parts or the vehicle
- > Heavy-duty, two-way zipper for easy opening and closing

# MULTI-USE PAINT STAND

Rubber sleeves  
protect support arms  
from overspray

**NEW**

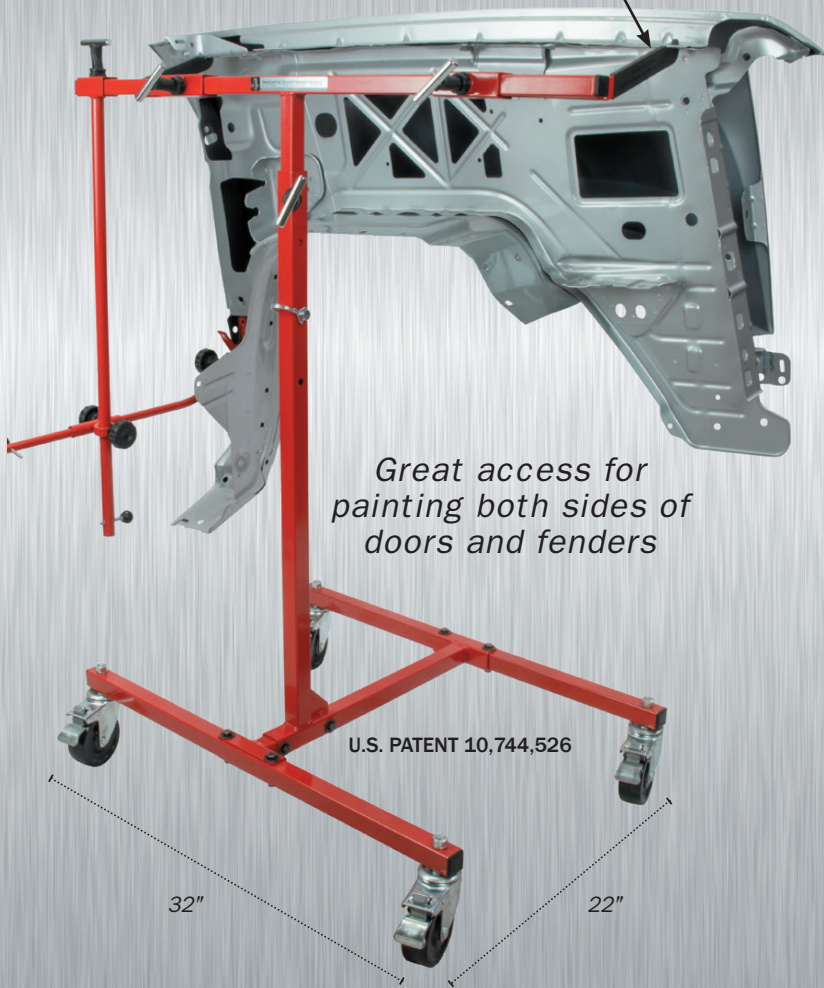

Great access for  
painting both sides of  
doors and fenders

U.S. PATENT 10,744,526

32"

22"

Innovative Door-Fender Single™

## Make Your Spray Booth More Efficient



Spray panels just like they mount and line up on the vehicle for  
the best color and texture matches and **no missed edges!**

### Innovative Door-Fender Single

#### Part # I-DFS

- > Securely holds a fender or door
- > Complete paint coverage inside and out
- > Easily adjusts to perfect working height
- > Eliminates missed edges
- > Mount parts in the same positions as on the vehicle for best color and texture match

- > Wide stance adds uncompromised stability
- > Protective rubber boots keep critical areas free of overspray
- > 4" industrial-grade Total-Lock caster wheels for stable mobility; zero movement when locked
- > Durable powder-coat finish
- > Three-year warranty
- > 32"W x 22"D x 40"H
- > Weight rating: 50 lbs.

### NEW! Wider Wheels

Avoid getting stuck in  
spray booth floor grates

- > 4" x 1.5" Total-lock wheels provide zero movement with the touch of a toe





# Painting Large Panels Just Got a LOT Easier!



## Replacement Rubber Sleeves

### Part # I-DF-RS12

- > Fits Door-Fender Single only
- > Easy to change
- > 12 sleeves per package

*We recommend changing sleeves every two months to reduce maintenance time and eliminate excessive overspray*



## Innovative Door-Fender Cargo Door Option

### Part # I-DFC

- > Mount cargo door in the same position as on the vehicle for best color and texture match



*The largest cargo doors are held securely for painting and moving in and out of the booth*

Mercedes Sprinter Cargo Door

*Door-Fender Single Option provides great access for painting **both sides** of the cargo door*



*Above photo shows Cargo Door Option in stored position on the Door-Fender Single base*

For usage video of the Door-Fender Single, visit

**InnovativeTools.com**

# INNOVATIVE OCTOPUS PAINT STAND™

EVER NEED AN EXTRA HAND IN THE PAINT BOOTH?  
HOW ABOUT EIGHT!

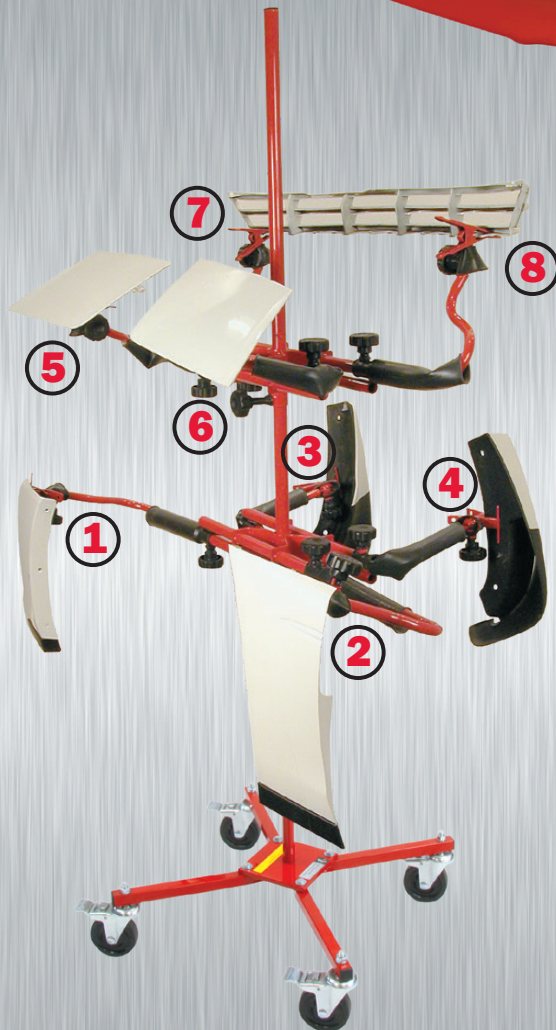

## Innovative Octopus™

U.S. PATENT 7,445,184

### Innovative Octopus™

**Part # OPR**

U.S. PATENT 7,988,137

- > Securely holds small parts such as moldings, flares, fuel doors, etc.
- > Easily adjusts to perfect working height
- > Eliminates missed edges
- > Mount parts in the same position as on the vehicle for best color & texture match
- > Protective rubber boots keep critical areas free of overspray
- > 4" industrial-grade, total-lock caster wheels for stable mobility; zero movement when locked
- > Durable powder-coat finish
- > Three-Year Warranty
- > 24"W x 24"D x 70"H
- > Support arms adjustment 13"W - 44"W
- > Weight rating 25 lbs.



- > 4" Total-lock wheels provide zero movement with the touch of a toe

NEW



### Innovative Magnetic Mirror Mount

**Part # I-MRM**

- > Securely holds mirrors just like they mount on the vehicle
- > Strong rubber-coated magnets hold fast to any metal surface without scratching

NEW

### Innovative Magnetic Clamp Holder

**Part # I-MCH**

- > Securely holds door handles, gas doors and other small parts
- > Strong rubber-coated magnets hold fast to any metal surface





# INNOVATIVE ULTRARACK PAINT STAND™

“We had two other brands of painting racks in our shop. Once we bought a couple of UltraRacks, it was hard to get anyone to use the others any more. This rack is five stars in my book.”



**NEW!**

Center support hook for hood latch mounting

## Innovative UltraRack™

### Part # URPS

- > Holds hoods, tailgates, doors, lift gates, deck lids, cargo doors and fenders
- > Efficient single-hand operation, uninterrupted spraying
- > Complete paint coverage inside and out
- > Seven locking positions mimic the part's position on the vehicle for a seamless match
- > Complete system - no accessories needed to buy
- > Rotates panel 90 degrees to ensure proper paint coverage every time
- > Protective rubber boots keep critical areas free of overspray
- > 4" industrial-grade, total-lock caster wheels for stable mobility; zero movement when locked
- > Durable powder-coat finish
- > 32"W x 32"D x 54"H
- > Support arms adjustments 15"W - 64"W x 12"H x 56"H
- > Weight rating 75 lbs.

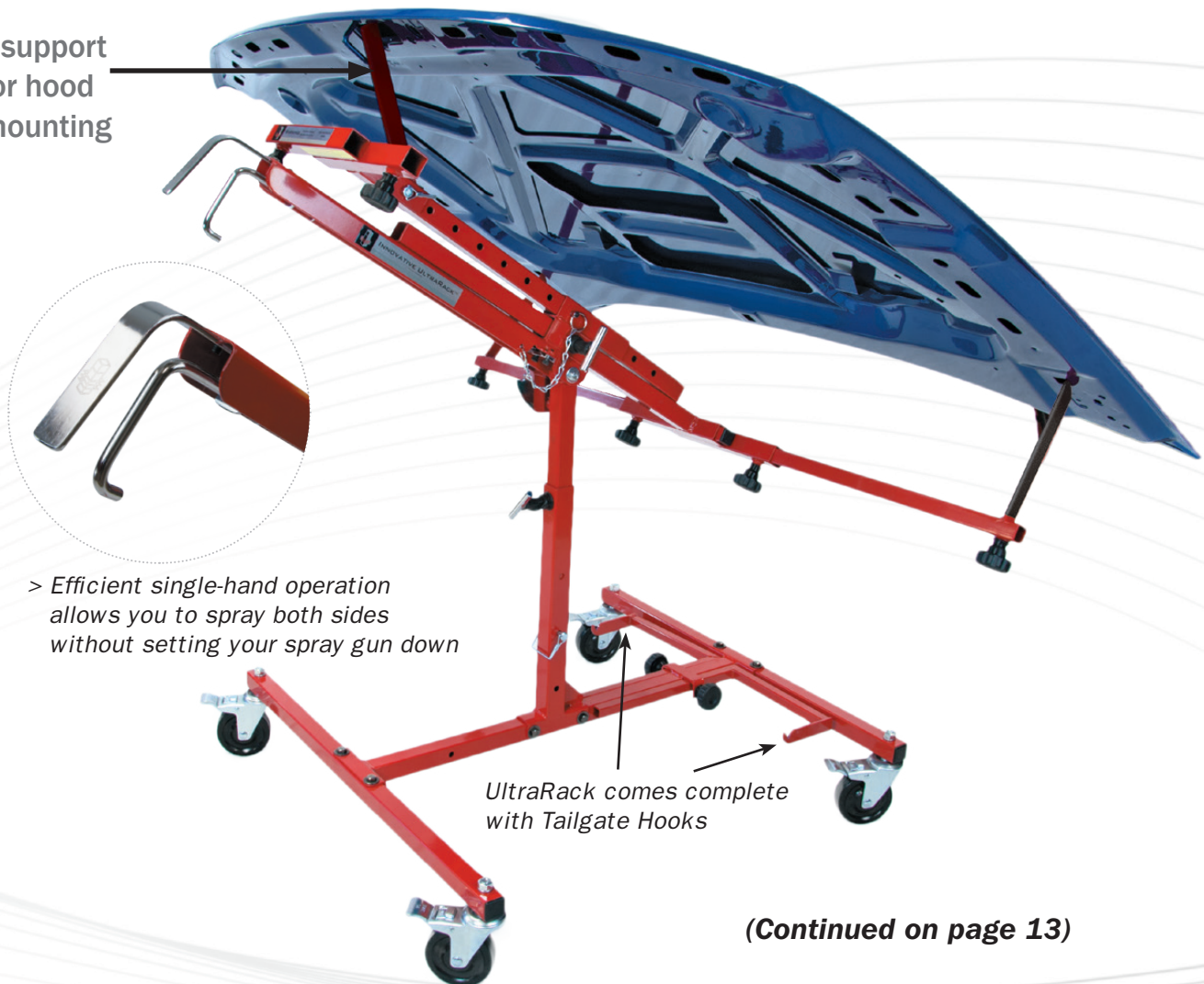

- > Efficient single-hand operation allows you to spray both sides without setting your spray gun down

UltraRack comes complete with Tailgate Hooks

**(Continued on page 13)**

# PAINT & REPAIR STANDS



Innovative UltraRack™

Part # URPS

U.S. PATENT 7,448,606

*All Innovative Paint Racks mount parts in the same position as on the vehicle for best color & texture match*

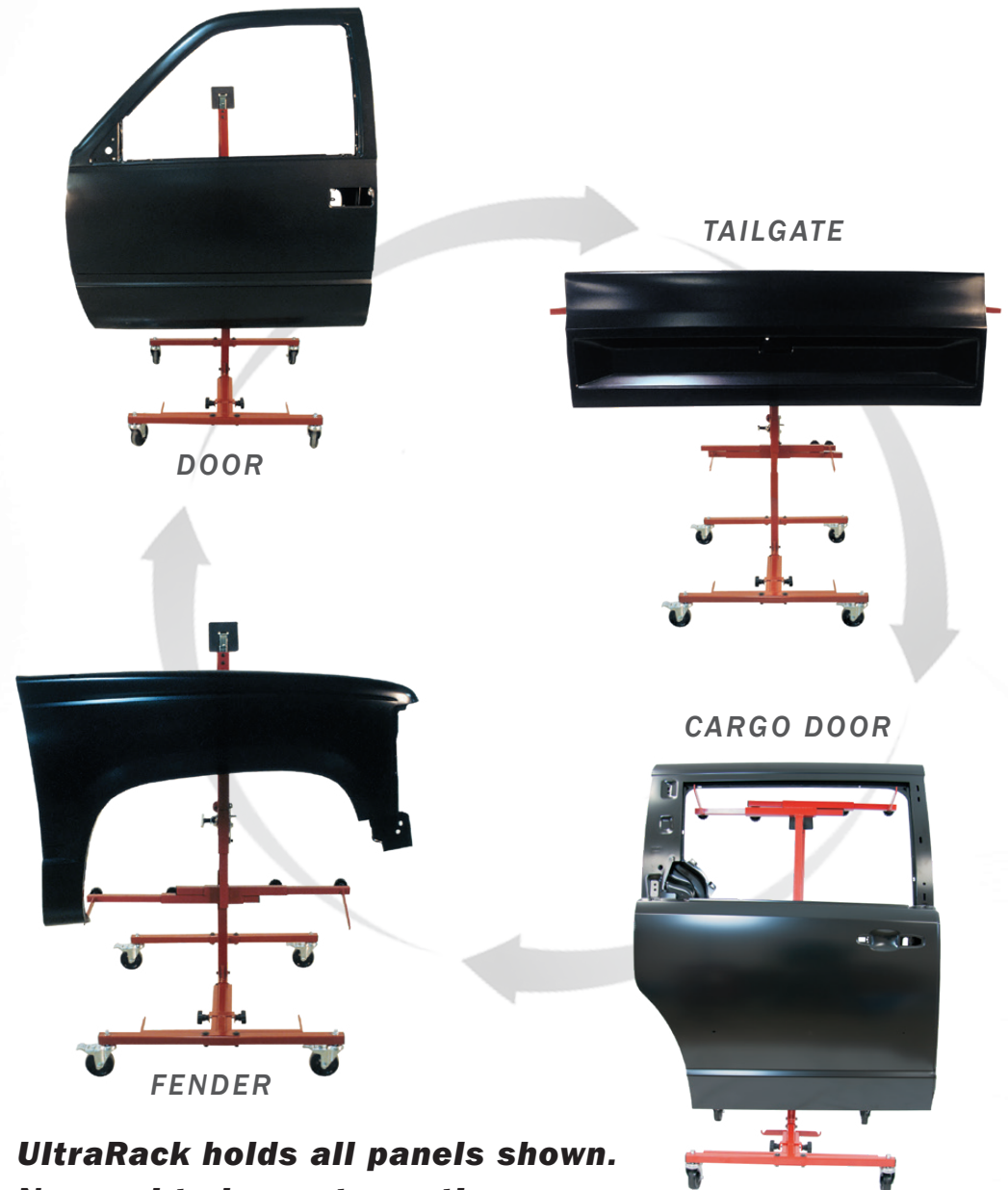

**UltraRack holds all panels shown.  
No need to buy extra options.**



**NEW**



**Replacement Rubber Sleeves**

**Part # URPS-R20**

- > Fits UltraRack support arms only
- > Easy to change
- > 20 sleeves per package

*We recommend changing sleeves every two months to reduce maintenance time and eliminate excessive overspray*

**NEW**



**Replacement Rubber Sleeves**

**Part # URPS-CHR10**

- > Fits UltraRack center hook only
- > Easy to change
- > 10 sleeves per package

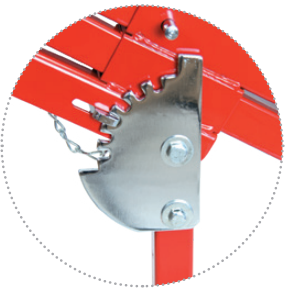

- > Seven locking positions allow you to mount parts in the same position as on the vehicle for the best color and texture match

**NEW! Wider Wheels**

Avoid getting stuck in spray booth floor grates



- > 4" x 1.5" Total-lock wheels provide zero movement with the touch of a toe



# Optional Wheel Mounts

for Innovative UltraRack™



**Part # URPS-WM**

Comes complete as shown above  
Weight rating 40 lbs. per support arm



*Optional Wheel Mounts come in red. Wheel Mount is shown in black for demonstration purposes only.*

**Ultrarack sold separately**

The optional Wheel Mounts will give you the ability to paint up to four wheels at a time, with the ability to spin the wheels making painting quick and easy.

*Standard UltraRack does not come with Wheel Mount option*

# SUPERSTAND 6™

DESIGNED TO HOLD THE MOST DIFFICULT  
BUMPER COVERS IN THE WORLD!

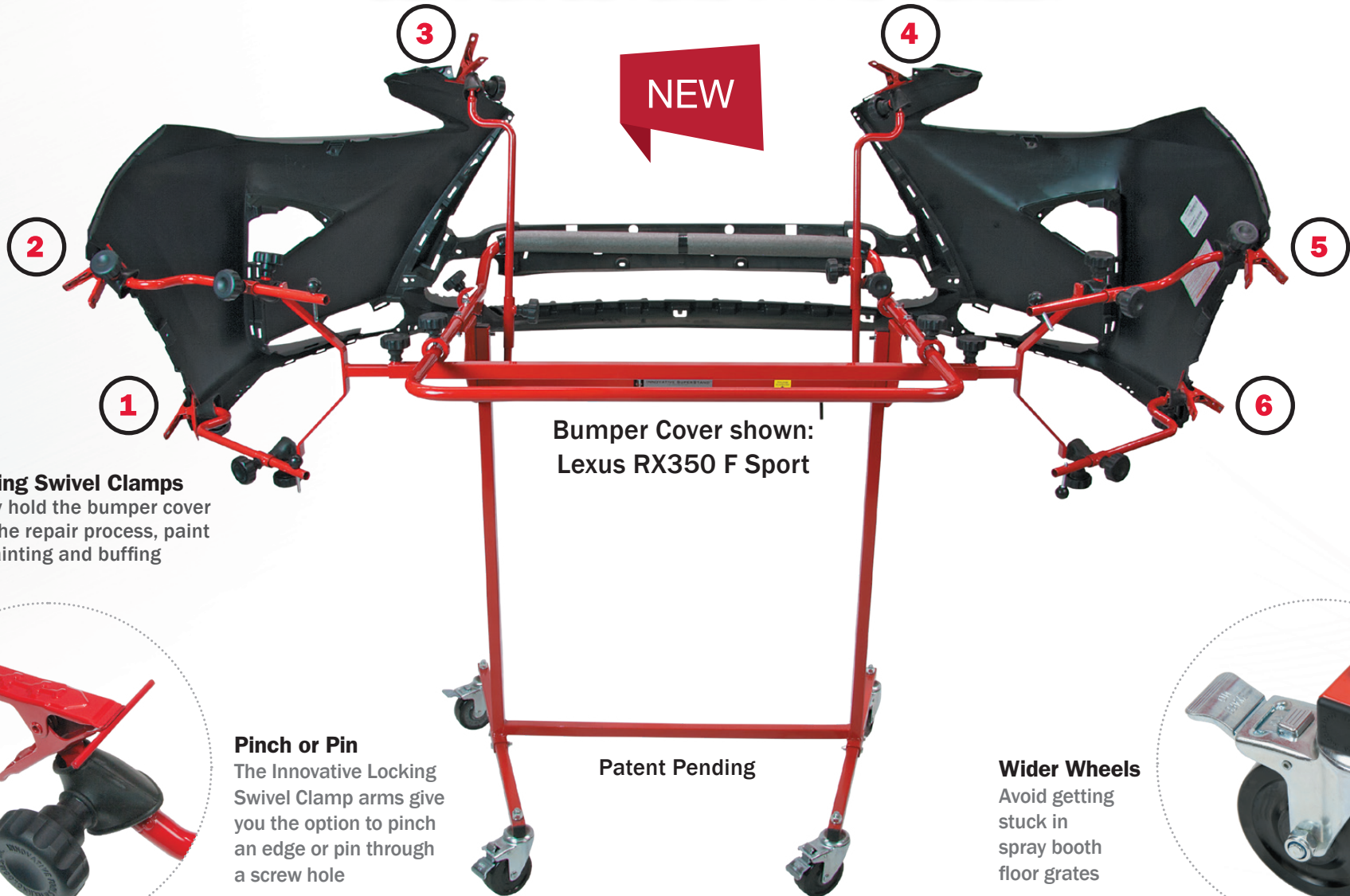

NEW

Bumper Cover shown:  
Lexus RX350 F Sport

> **6 Locking Swivel Clamps**  
securely hold the bumper cover  
during the repair process, paint  
prep, painting and buffing

**Pinch or Pin**  
The Innovative Locking  
Swivel Clamp arms give  
you the option to pinch  
an edge or pin through  
a screw hole

Patent Pending

**Wider Wheels**  
Avoid getting  
stuck in  
spray booth  
floor grates

For usage video of the SuperStand 6,  
visit [InnovativeTools.com](http://InnovativeTools.com)

> 4" x 1.5" Total-lock wheels  
provide zero movement with  
the touch of a toe





## Innovative SuperStand 6™

### Part # SS-6

- > Holds the most difficult plastic bumper covers securely without touching the painted surface
- > Makes repairs, prep and painting faster and easier
- > Cover can be rotated 90 degrees to ensure proper paint coverage time after time
- > Five locking positions for a perfect angle every time
- > Protective rubber boots keep critical areas overspray-free
- > 4" industrial-grade, total-lock caster wheels for stable mobility; zero movement when locked
- > Durable powder-coat finish
- > 44"W x 30"D x 53"H
- > Weight rating 35 lbs.

The SuperStand 6 is the first and only universal mobile clamping system that securely holds the most difficult bumper covers in the world! This speeds up the repair and prep process by allowing the tech to use a D.A. sander and other air tools that will save countless hours of labor. No missed edges and no distortion during the baking process means that the cover will perfectly fit on the vehicle each and every time.



Cadillac Escalade

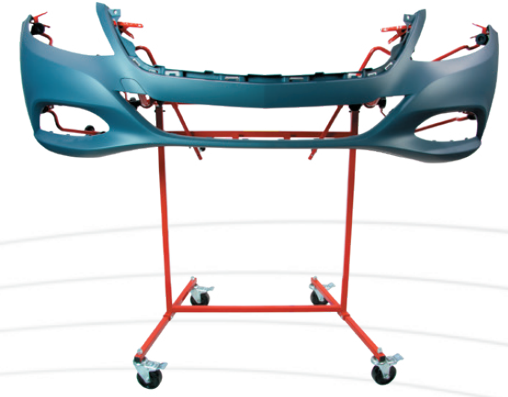

Mercedes Benz S550



BMW 7 Series



Tesla Model S



Toyota Avalon



Dodge Charger

# INNOVATIVE SUPERSTAND 2™

## MAKES BUMPER PAINTING & REPAIR EASY

RELIABLE :: DURABLE :: EFFICIENT :: GUARANTEED



> **Pinch or Pin**  
*The Innovative Locking Swivel Clamp arm gives you the option to pinch an edge or pin through a screw hole.*

**NEW!**  
**Wider Wheels**  
Avoid getting stuck in spray booth floor grates

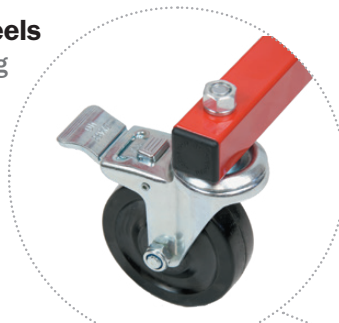

> *4" x 1.5" Total-lock wheels provide zero movement with the touch of a toe*



> *Nestable storage*

Innovative SuperStand 2™



Spray your bumper covers just like they mount on the vehicle for the best color and texture matches and **no missed edges!**



Total Lock Wheel  
Part # 4TLCW

Total Lock Wheel  
Part # 4TLCW

Fits:

- > Most Innovative Products

### Innovative SuperStand™

#### Part # SS-2

U.S. PATENT 6,173,947

- > Holds most plastic bumper covers securely without touching the painted surface
- > Makes repairs, prep and painting faster and easier
- > Cover can be rotated 90 degrees to ensure proper paint coverage time after time
- > Five locking positions for a perfect angle every time
- > Protective rubber boots keep critical areas overspray-free
- > 4" industrial-grade, total-lock caster wheels for stable mobility; zero movement when locked
- > Durable powder-coat finish
- > 44"W x 30"D x 53"H
- > Weight rating 25 lbs.



Replacement Swivel Clamp  
Support Arm Kit  
fits SuperStand 2

### Replacement Swivel Clamp Support Arm Kit

#### Part # SAS

Includes:

- > 1 Right swivel clamp support arm
- > 1 Left swivel clamp support arm
- > 2 Plastic hand knobs
- > 2 Rubber sleeves
- > 2 Ball socket boots
- > No assembly required



Part # SS-2

# INNOVATIVE PAINT STATION™

MAKES PAINTING SMALL PARTS QUICK & EASY



NEW



The Innovative Paint Station, with its four strong removable Swivel Clamp Arms can hold mirror covers, door handles and all other miscellaneous parts securely in seconds.

The large, clean work surface makes painting side moldings a snap! The Innovative Paint Station will pay for itself in a short period of time through increased productivity.

## Innovative Paint Station™ Part # I-PS

- > Four removeable Swivel Clamp Arms
- > Small footprint
- > Two spray gun holders for working on multiple jobs
- > Easily adjusts to your perfect working height
- > Uses standard 18" masking paper
- > Durable powder coat finish
- > 4" x 1.5" industrial grade caster wheels. Two of the wheels are total-lock.
- > Trash can included
- > Weight rating: 40 lbs.
- > 41" w x 23" d x 72" h

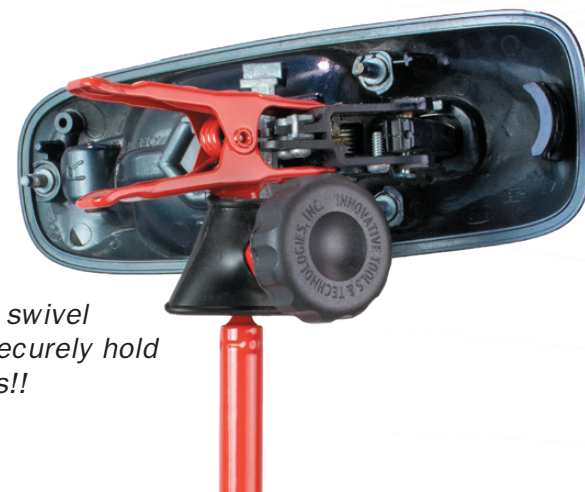

> Four incredibly strong swivel clamps allow you to securely hold small parts in seconds!!





**Innovative Multiple  
Spray Gun Holder**  
*Part # I-SGH-7*



**Innovative Magnetic  
Multiple Spray Gun Holder**  
*Part # I-MMSGH-7*



**Innovative Magnetic Spray Gun Holder™**  
*Part # I-MSGH*

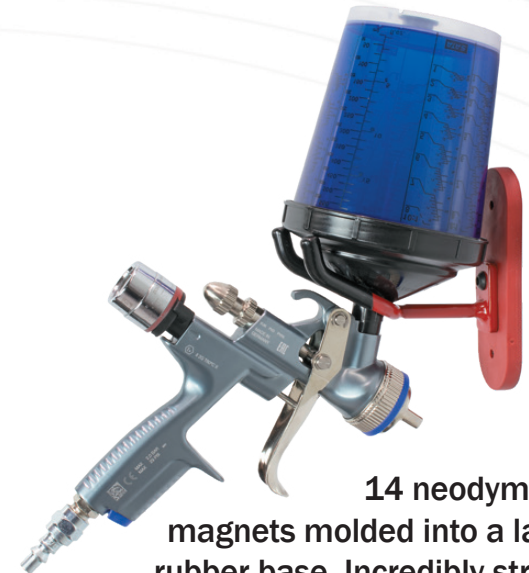

**14 neodymium magnets molded into a large rubber base. Incredibly strong. Will not scratch booth walls.**

# INNOVATIVE SPRAY GUN CABINETS

NEW



*The Deluxe Cabinet has an additional mounting bar underneath the cabinet for holding three spray guns with cups*

## Innovative Spray Gun Cabinet Deluxe™

**Part # I-SGCD**

Patent Pending

- > Door is designed to flip up and stay out of your way
- > Keep your expensive spray guns safe and secure
- > Holds up to six spray guns
- > Programmable digital cabinet lock
- > Heavy duty construction
- > Powder coat finish
- > Limited lifetime warranty
- > Weight: 33 lbs.

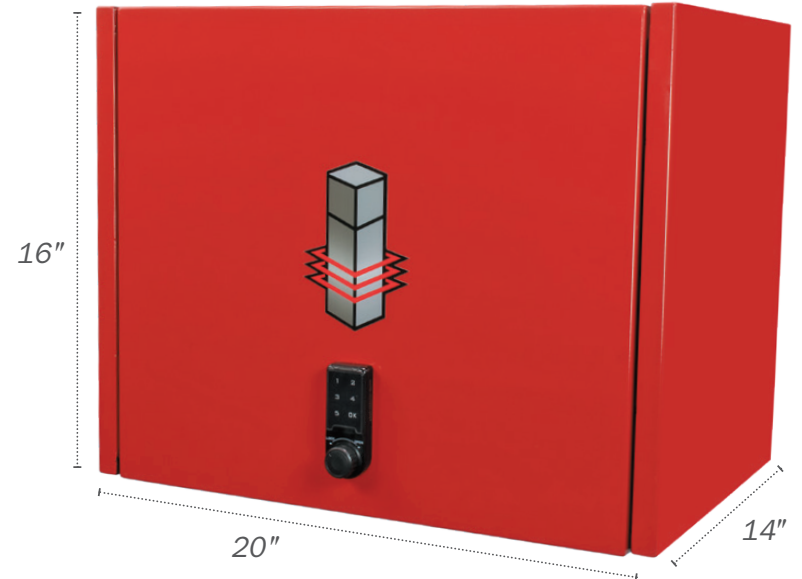

## Innovative Spray Gun Cabinet™

**Part # I-SGC**

Patent Pending

- > Door is designed to flip up and stay out of your way
- > Keep your expensive spray guns safe and secure
- > Holds up to six spray guns
- > Programmable digital cabinet lock
- > Heavy duty construction
- > Powder coat finish
- > Limited lifetime warranty
- > Weight: 31 lbs.

The six spray gun holder inside the cabinet has a rubber coating that protects against damage





# INNOVATIVE ESTIMATING CART

**Look professional from the start... with the Innovative Estimating Cart!**



12° tilt adjustment



Tabletop height adjustment ranges from 38" to 48"

26"

24"

Now you can roll your mobile desk right next to the vehicle, whether you're in the estimating bay or out back in a gravel parking lot.

The large locking drawer lets you securely store your laptop, inspection light, magnetic arrow system, markers, etc.

The Innovative Estimating Cart will save time and make a great first impression on your customer!

## **Innovative Mobile Estimating Cart™**

**Part # I-MEC**

Patent # D916530

- > Non-slip rubber work surface
- > Easily adjusts to perfect working height
- > Locking drawer
- > Rubberized drawer liner
- > Work surface 24" x 19"
- > Drawer size 20" x 16" x 3"
- > Weight 92 pounds
- > Heavy-duty construction
- > Durable powder-coat finish
- > Lifetime Warranty



- > Two locking and two non-locking casters
- > Industry's ONLY 8" solid rubber total-lock wheels for complete mobility, stability and zero movement when locked. Rolls easily through gravel.

# Estimating Cart Accessories



**See everything the first time.**  
Multimatch R with its magnetic base allows you to put the light exactly where you need it



**Matchpen™**  
**Part # SG-MP**

The Matchpen's high CRI of 95 light puts sunlight in your hand for quick spot inspections.

**SPECIFICATIONS**  
Ultra high 95 CRI LED  
4000 KELVIN  
100 lumen  
10°-70° beam angle  
2X AAA/1.5V Alkaline



**Multimatch R with built-in Magnetic Mount**  
**Part # SG-MMR**

Using the Multimatch R, with its ultra-high CRI of 96 and incredible 1200 Lumens, illuminates large areas, making it easy to identify damage, down low or under the hood.

*For Multimatch R product specifications, see page 25*



# LED SOLUTIONS FOR FAST UV CURING

**SCANGRIP®**  
UV CURING

**NEW**



**NOVA**

**Part # SG-NOVA-UVS**

**Cure Area**

**8"**

**3 YEAR WARRANTY**



**UV-GUN**

**Part # SG-UV GUN**

**> 1 minute cure time**

**Cure Area**

**26"**

# MULTIMATCH R

Handheld high **CRI+** LED work light with ALL DAYLIGHT

# PERFECT LIGHT!



**Multimatch R**  
Part # SG-MMR

### TECHNICAL SPECIFICATIONS

Ultra high **CRI+** COB LED  
 96 **CRI+**  
 2500-6500 KELVIN  
 250-2500 lux@0.5m  
 1200 lm@100% / 1125lm@75%  
 / 600lm@50% / 300lm@25% /  
 120lm@10%  
 1-10h operating time  
 3.5h charging time  
 3.7V/5400mAh Li-ion

Handy and powerful work light for inspection and detailing providing up to 1200 lumen.

MULTIMATCH R features the outstanding ALL DAYLIGHT function, providing you with the option to choose between 5 different color temperatures depending on the job.

The lamp is easy to carry and is ergonomically designed for a good grip on the handle, which is also equipped with powerful integrated magnets for flexible mounting. This gives you high flexibility and application possibilities for internal inspection of cars and other narrow areas.

The lamp is designed for direct mounting on the SCANGRIP TRIPOD and WHEEL STAND.

Rechargeable built-in power bank with USB outlet to charge mobile devices.

Dimensions: 6.5" x 6.5"

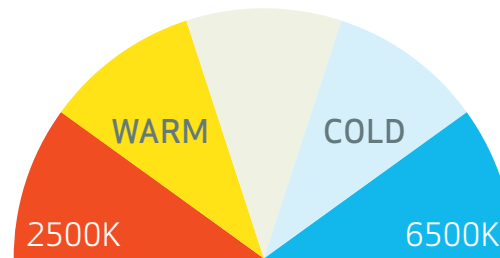
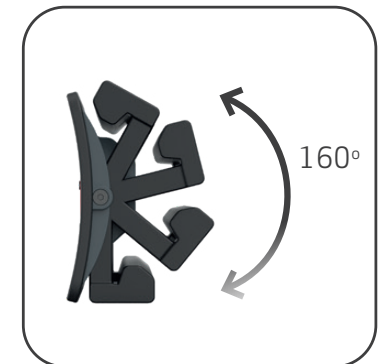

ALL DAYLIGHT - 5 step





# MULTIMATCH 3

High **CRI+** LED work light with exchangeable batteries

Outstanding and powerful rechargeable work light providing up to 3000 lumen for inspection of large surfaces during polishing, painting and cleaning operations as well as for color match.

The work light features the unique ALL DAYLIGHT function, providing you with the option to choose between 5 different colour temperatures. The 5-step dimmer function makes it possible to adjust the light into five different levels depending on the job at hand.

The new SCANGRIP POWER SOLUTION provides you with unlimited availability to light. Easily you can insert a new fully charged battery and continue the work while another battery is charging. Or you can simply add the charger directly to the lamp to get power supply. The integrated battery backup function prevents you from being without light at any time.

With the new BLUETOOTH lighting control app you are able to control and adjust both the light output and the colour temperatures, along with a range of other useful, wireless functions improving daily work efficiency.

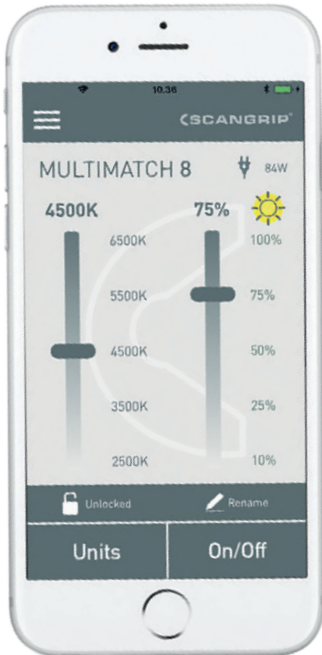

**Multimatch 3**  
Part # SG-MM-3



Multimatch 3 shown mounted on optional wheelstand  
Option Part # SG-TWS

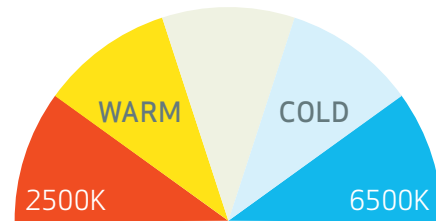

## TECHNICAL SPECIFICATIONS

Ultra high **CRI+** COB LED  
 96 **CRI+**  
 2500-6500 KELVIN  
 450-4500 lux@0.5m  
 3000 lm@100% / 2250 lm@75% /  
 1500 lm@50% / 750 lm@25% / 300 lm@10%  
 1.5-15h operating time, Backup: 2h@10%/300lm  
 1.5 charging time @80%  
 11.1V/4000mAh Li-ion, Backup: 7.4V/1000mAh  
 100-240 AC operating voltage  
 IK07  
 IP67  
 1.97 kg  
 incl. SPS BATTERY 4Ah 03.6003 and SPS  
 CHARGING SYSTEM 35W 03.6006

# SUNMATCH 4

High **CRI+** LED work light with ALL DAYLIGHT

**SUNLIGHT IN YOUR HAND!**



**Sunmatch 4**  
Part # SG-SM-4

Handheld rechargeable work light with excellent color rendering properties, for perfect color match.

Depending on the type of job at hand, SUNMATCH 4 features an outstanding ALL DAYLIGHT function, providing you with the option to choose between 5 different color temperatures. A spotlight for inspection is included at the top. Supplied with a two-step operating option.

Place the lamp anywhere you want during inspection with the turnable sturdy hook or the strong built-in magnet. The flexible lamp head tilts up to 180 degrees. Durable construction, dust as well as waterproof, IP65. Supplied with solvent resistant glass lens. Battery indicator at front shows when the battery must be recharged.

To avoid overheating the built-in intelligent heat protection system switches to low mode (50%) after 3 minutes continuous use at high mode.

Easy to carry in the pocket or in the work belt with the built-in clip, ready at hand for quality check between prep-zone operations. SUNMATCH 4 is always ready to use and easy to find when placed in its charging base after each job.

**Now comes with light diffuser.**

**NEW**  
UPGRADED  
VERSION

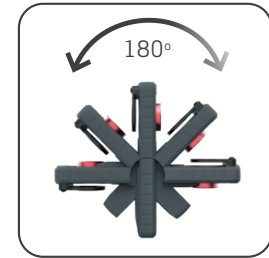

Including 1x SCANGRIP  
DIFFUSER SMALL



Stepless dimmer  
10-100%

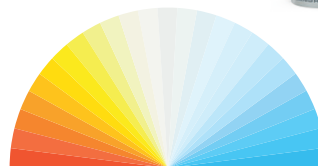

CCT SCAN - Stepless

**SCANGRIP®**



## TECHNICAL SPECIFICATIONS

Ultra high **CRI+** COB LED / Spot: High power LED  
 96 **CRI+**, Spot: 95 CRI  
 2500-6500 KELVIN, Spot: 4000 KELVIN  
 50/500 lumen, Spot: 200 lumen  
 700/1400 lux@0.5m, Spot: 5000 lux@0.5m  
 2-10h operating time, Spot: 3h  
 4h charging time  
 3.7V/2600mAh Li-ion



# WORLD'S ONLY COLOR CORRECTIVE HEADLAMP

For the Professional who needs Perfect Lighting

The new I-MATCH 3 features a 2 COLOR LIGHT function. This provides you with the option to choose between 2 different color temperatures depending on the type of job to be carried out. Typically, the WARM LIGHT (2500K) is useful for bright surfaces, and COLD LIGHT (6500K) is ideal for dark colored surfaces.

Supplied with the newest COB LED technology, the new, rechargeable I-MATCH 3 provides an extremely powerful illumination spreading the uniform light to the maximum and lightens up your entire field of view.

By waving your hand in front of the lamp, you will switch on the light when needed. In sensor mode, the light can easily be switched on/off, even when wearing gloves.

I-MATCH 3 is provided with the very newest rechargeable battery technology with long operating time, and sets new standards for professional work light.

Supplied with lumen output options of 25 to 250. The robust and sleek I-MATCH 3 is both dust and waterproof (IP65) with a remarkably low weight, only 4 oz., making it extremely comfortable to wear.

## TECHNICAL SPECIFICATIONS

- Ultra high CRI+ COB LED
- 96 CRI+
- 2500/6500 KELVIN
- 60/600 lux
- 25/250 lumen
- 1.5h - 15h operating time
- 3.8V/1600mAh li-poly
- 3.5h charging time



Stepless dimmer  
10-100%

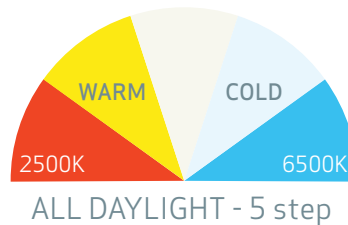

**I-MATCH 3**  
*Part # I-MATCH 3*



**World's only headlamp that acts like a flood light**

Lights up your entire field of view



Standard  
headlamp



I-MATCH 3  
headlamp

# POINT OF USE MATERIAL CARTS



## Innovative Paint Prep Cart with Masker™

**Part # I-MCWM**

PATENT #US 9,737,141 B2

# Make Your Supplies Mobile & Organized

	Innovative Paint Prep Cart™ with Masker Part # I-MCWM	Innovative Paint Prep Cart™ Part # I-MCPC	Innovative Detailer Cart™ Part # I-MCDC	Innovative Bodyman Cart™ Part # I-MCBM
BARCODE TAG HOLDERS	50	50	50	50
SINGLE HOOK Part # I-SH	4	4	4	4
DOUBLE HOOK Part # I-DH	2	2	2	2
ROLL PAPER HOLDER Part # I-RSH	1	1	-	1
4X17" BASKET Part # I-4x17	1	1	1	3
5X17" BASKET Part # I-5X17	1	1	-	2
7X17" BASKET Part # I-7X17	3	3	2	2
8X17" BASKET Part # I-8X17	-	-	1	1
AEROSOL BASKET Part # I-CH	1	1	3	1
GLOVE BOX HOLDER Part # I-GB	1	1	1	1
MASKER OPTION Part # I-MO	1	-	-	-
LARGE BOX MOUNT Part # I-BM	2	-	-	1
9 BOTTLE HOLDER Part # I-9B	-	-	-	1
5" DISK HOLDER Part # I-DH5	-	-	-	1
BUFFER PAD HOLDER Part # I-PH	-	-	1	-
TRASH CAN Part # I-TC	1	1	1	1
SPRAY GUN HOLDER Part # I-GH	1	1	-	1

Base Material Cart Measurements > Height 67" | Width 35" | Depth 22"



# Keep Your Techs On Task!!



**Innovative Paint Prep Cart™**  
**Part # I-MCPC**  
 PATENT #US 9,737,141 B2



**Innovative Detailer Cart™**  
**Part # I-MCDC**  
 PATENT #US 9,737,141 B2



**Innovative Bodyman Cart™**  
**Part # I-MCBM**  
 PATENT #US 9,737,141 B2

**Every Innovative Material Cart:**

- > Conveniently stores material & supplies in full view at any angle
- > Rolls right into your work area for greater efficiency
- > Facilitates easy-to-use bar code system; tags provided
- > Eliminates extra trips to the supply room; keeps technicians on the job, saving time and money
- > 4" industrial-grade, total-lock caster wheels for stable mobility; zero movement when locked
- > Durable powder-coat finish
- > Lifetime warranty

# POINT OF USE ADHESIVE CART



## Innovative Adhesive Cart™

Part # I-MCAC

Patent #US 9,737,141 B2

## Quit wasting expensive materials!



Keep partially used tubes up front to be used first, with the new backup tubes waiting right behind them. No more misplaced, partially used tubes lost in cabinets or on shelves.

### Includes:

- > 1 Shelf Mat - Part # I-SM
- > 1 Aerosol basket - Part # I-CH
- > 1 Applicator Gun Holder - Part # I-AGH
- > 1 Tray 2-Section - Part # I-T2
- > 2 Tray 3-Section - Part # I-T3
- > 8 U-Hook - Part # I-UH
- > 2 Single Hook - Part # I-SH
- > 50 Barcode Tag Holders
- > 1 Trash Can - Part # I-TC
- > 1 Glove Box Holder - Part # I-GB
- > 1 Large Box Mount - Part # I-BM
- > 1 Box Holder - Part # I-BH
- > 1 Quad Bottle Holder - Part # I-QH
- > 3 9-Bottle Holder - Part # I-9B
- > 2 Hex Bottle Holder - Part # I-HB

### Features, Advantages:

- > Monitor & track repair materials
- > Everything needed for the job in one portable location
- > Open wire design allows quick and easy inventory count at a glance
- > Eliminates extra trips to the supply room, keeps technicians on the job – saving time and money
- > By keeping the partial used tube in front with two full back-ups behind it, techs never run out of material at a critical time
- > Multiple techs can work from one cart
- > Durable powder-coat finish
- > Easy to rotate inventory; no more expensive products expiring
- > Lifetime Warranty



# MATERIAL CART ACCESSORIES

## Innovative Masker Option

**Part # I-MO**

- > Holds one roll of 6" to 12" paper and two rolls of 18" paper.
- > Thick steel blades allow for longevity while maintaining smooth cutting
- > Easy loading of paper rolls and tape
- > Heavy-duty all steel construction
- > Durable powder-coat finish
- > Lifetime warranty



## Innovative Vertical Masker Option



> Lower cup design allows trouble-free vertical dispensing

## Innovative Vertical Masker Option

**Part # I-MO36** Patent #10,143,300

- > A must-have option for the Innovative Material Cart w/Masker
- > Industry's only stainless steel tear blade for clean, smooth cuts
- > Plastic sheeting dispenses from factory box, keeping it dust free
- > Nylon bushings for easy material rotation
- > Heavy-duty all-steel construction
- > Durable powder-coat finish
- > **Lifetime Warranty**
- > 12"W x 18"D x 44"H

## Shelf Mat

**Part # I-SM**

- > A great addition to any Material Cart
- > Durable, easy-to-clean, chemical resistant work surface
- > Helps avoid losing small clips and parts

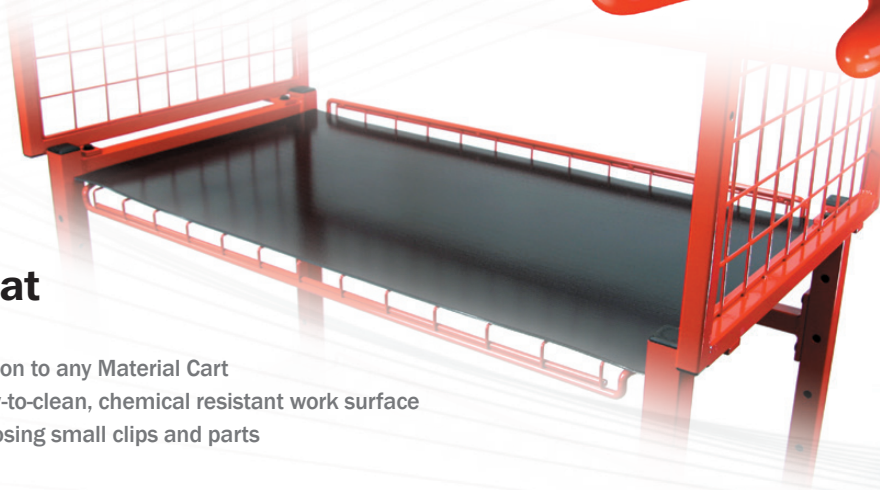

# MATERIAL CART ACCESSORIES



**Quad Bottle Holder**  
Holds 4 cartridges  
**Part # I-QH**



**D.A. Sander Holder**  
**Part # I-DAH**



**5" Disc Holder** **Part # I-DH5**  
No more curled discs  
Keeps discs perfectly flat



**U-Hook**  
**Part # I-UH**



**9 Bottle Holder**  
**Part # I-9B**



**Dynamic Mixing Gun Holder**  
**Part # I-AGH**



**Tray 2-Section**  
**Part # I-T2**  
11"W x 5"D x 3"H



**Single Hook**  
**Part # I-SH**



**Hex Bottle Holder**  
Holds 6 cartridges  
**Part # I-HB**



**Slide Aerosol Basket**  
**Part # I-CHS**



**Tray 3-Section**  
**Part # I-T3**  
11"W x 5"D x 3"H



**Double Hook**  
**Part # I-DH**



**Spray Gun Holder**  
**Part # I-GH**



# INNOVATIVE GLASS STORAGE

## Innovative Wall Glass Rack™

Part # I-WGR

- > Holds 6 windshields
- > 2" wide flat steel base for very secure wall mounting
- > Extensive rubber and foam padding
  - no metal-on-glass contact
- > All mounting hardware included
- > Durable powder coat finish
- > Lifetime Warranty
- > 39"W x 26"D x 26"H
- > Weight Rating 150 lbs.



Extensive rubber padding

**14° pitchback for easy loading and unloading**

**Extensive rubber and foam padding – no metal-on-glass contact**

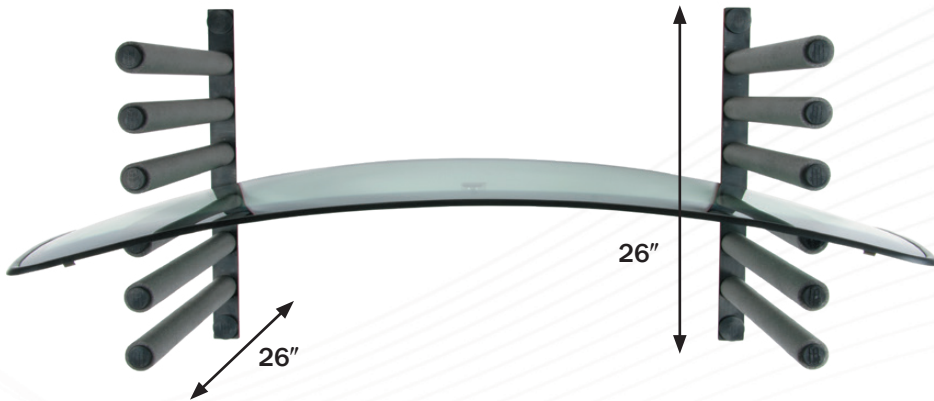
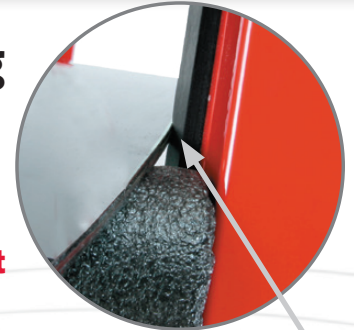

## Innovative Mobile Glass Rack™

Part # I-MGR

- > Holds 10 windshields
- > Extensive rubber and foam padding
  - no metal-on-glass contact
- > 14° pitchback for easy loading and unloading
- > Heavy gauge steel construction
- > Durable powder coat finish
- > Lifetime Warranty
- > 50"W x 45"D x 50"H
- > Weight Rating 300 lbs.

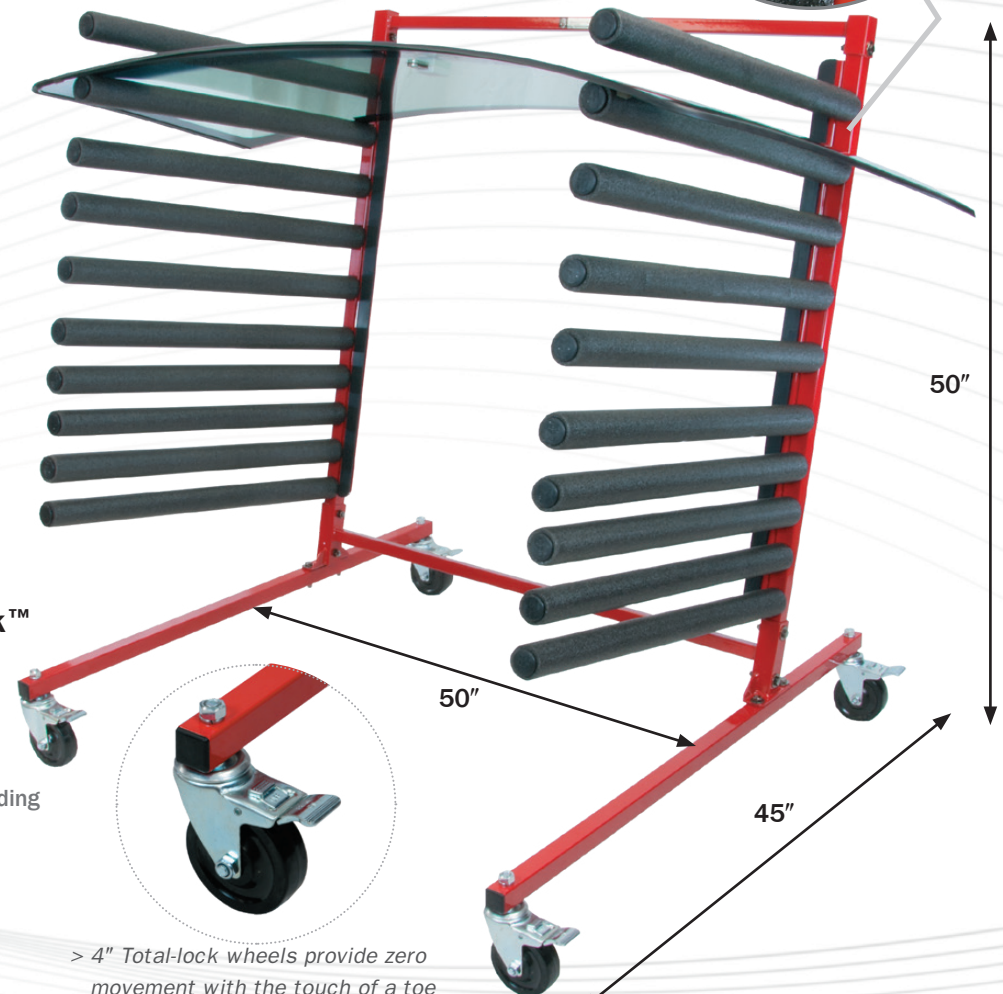

> 4" Total-lock wheels provide zero movement with the touch of a toe



# BUMPER & PANEL STORAGE



## Innovative Panel-Cart™

### Part # I-PC

- > Industry's only panel cart that folds up & stays up when not in use
- > Holds up to six large panels and glass
- > Extensive rubber & foam padding – no metal-on-metal contact; no damage
- > Can be used as whole or half unit
- > Sixteen posts and twenty-six post settings for custom adjustment (posts adjust every 2")
- > Support posts store with the cart
- > 4" Industrial grade, easy-glide, total-lock caster wheels for stable mobility; zero movement when locked
- > Folds to store in only 2 square feet of floor space
- > Durable powder-coat finish withstands rough handling
- > Lifetime Warranty
- > Weight Rating 400 lbs.

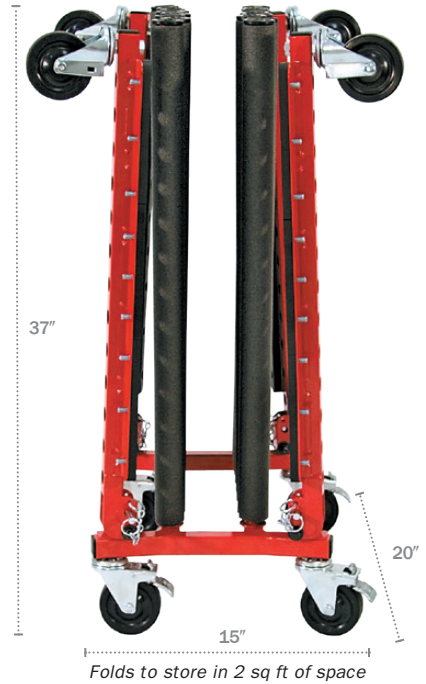

42"

Folded for half-usage mode

## Innovative Panel-Cart™



70"

Full-usage mode



# TAKE CONTROL OF YOUR PANEL & BUMPER STORAGE



## Innovative Wall Bumper Storage™

**Part # MBW**

U.S. PATENT 7,314,143

- > Holds 6 large bumper covers
- > Totally adjustable wall racking system puts big bumper covers in their place & saves space
- > Support arms adjust in 3" increments to accommodate large and small bumpers
- > Support arms fold down when not in use
- > Patented high-carbon, heat-treated steel brackets stands up to heavy loads
- > Can be mounted top-bottom (shown below) or side-by-side
- > Durable powder-coat finish withstands rough handling
- > Lifetime Warranty
- > 39"W x 23"D x 41"H - 82"H
- > Weight Rating 200 lbs.



One Innovative Wall Bumper holds **6 bumpers** (as shown)

### Includes:

- > Four Mounting rails
- > Twelve 23" Support arms
- > Mounting hardware



> Stores down flat when not in use



### Includes:

- > Eight 23" Support arms
- > Eight 18" Support arms

## Innovative Mobile Bumper Storage™

**Part # MBM**

U.S. PATENT 7,314,143

- > Holds 8 large bumper covers
- > Totally adjustable support arms put big bumper covers in their place & saves space
- > Support arms adjust in seconds to customise your storage needs
- > Eight extra-long arms for oversized bumper covers
- > Patented high-carbon, heat-treated steel brackets stands up to heavy loads
- > 4" locking wheels for easy mobility
- > Durable powder-coat finish, stands up to rough handling
- > Support arms adjust every 3"
- > 41"W x 37"D x 85"H
- > Lifetime Warranty
- > Weight Rating 250 lbs.

# INNOVATIVE DOOR-JACK



## ALLOWS ONE TECH TO DO THE JOB OF TWO



### Innovative Door-Jack™

**Part # I-DJ**

- > Now one tech can handle truck bumpers and doors alone
- > Ample padding, no metal-on-metal contact, no damage
- > Industry's only 8" front-to-back tilting adjustment
- > Side-to-side tilt adjustment for easier door removal & installation
- > Wide stance adds uncompromised stability
- > 4" industrial grade, easy-glide Total-lock caster wheels for stable mobility; zero movement when locked
- > Support Pads adjust from 7" to 32" from the floor
- > Heavy gauge steel construction
- > Durable powder-coat finish
- > Three Year warranty
- > Weight Rating 200 lbs.

> Support Pad adjustment ranges from 8" - 20"

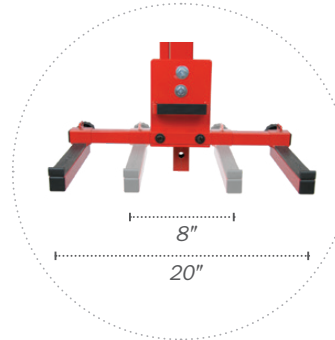

> 4" Total-lock wheels provide zero movement with the touch of a toe

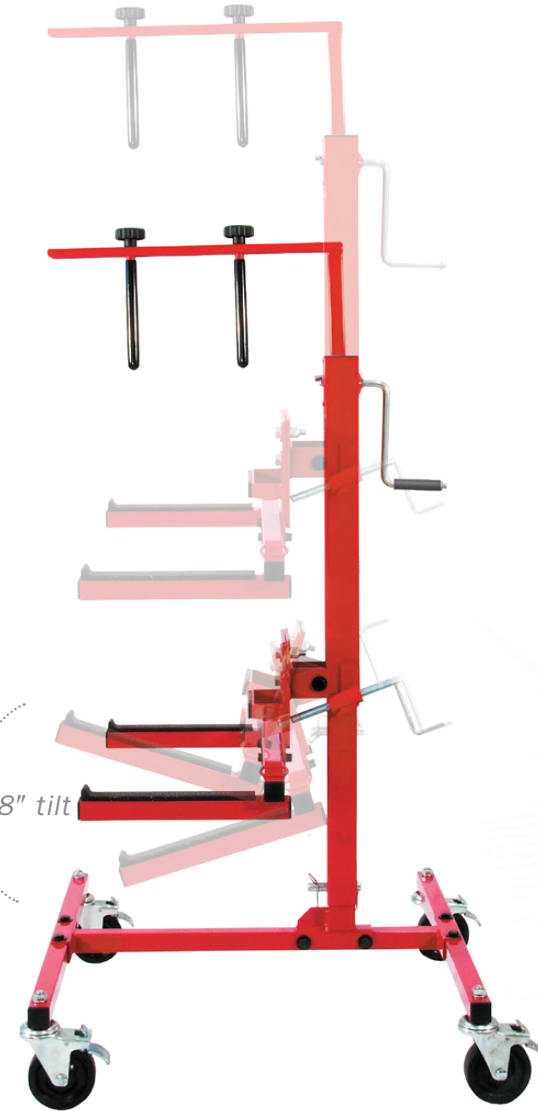



# HANDLE LARGE CARGO DOORS WITH EASE



Rubber-coated guide arms protect painted surfaces from damage.

## Innovative Door-Jack Option

**Part # I-DJO**

- > Handle huge cargo doors with ease!
- > Now, ONE TECH can remove and install a large cargo door without help
- > Durable powder coat finish
- > Lifetime warranty



**One tech ALONE can remove and install truck bumpers**



Above photo shows Door-Jack Option in stored position, which allows normal operation of the Door-Jack without interference.



For usage video of the Door-Jack and Cargo Door Option, visit

**InnovativeTools.com**

# INNOVATIVE TRUCK BED DOLLY

## SIMPLY THE BEST

### Innovative Truck Bed Dolly™

Part # I-TBD

- > Folds to the smallest footprint in the industry for space-saving storage
- > Easy 4-way adjustment to fit any size truck bed
- > Also holds panels and hoods
- > Multiple adjustments for ideal work height
- > Four rubber pads prevent truck bed from slipping
- > Solid rubber 8" total-lock caster wheels, never go flat, easy-glide with zero movement when locked
- > Weight rated to 600 lbs.
- > Durable powder-coat finish
- > Lifetime Warranty



Industry's **ONLY**  
freestanding folded-storage design



> Industry's **ONLY** 8" solid rubber total-lock wheels for complete mobility, stability and zero movement when locked

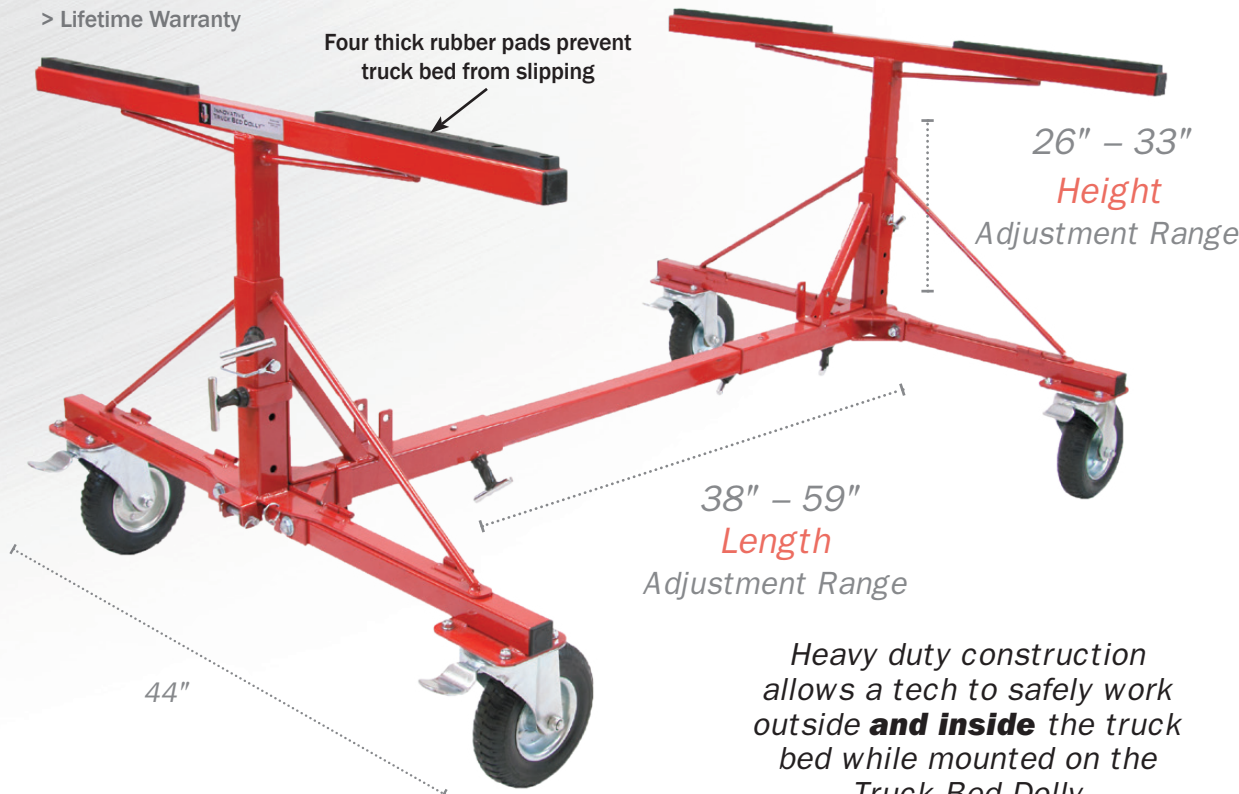

Heavy duty construction allows a tech to safely work outside **and inside** the truck bed while mounted on the Truck Bed Dolly



# INNOVATIVE BED LIFT



## Innovative Bed-Lift™ Part # I-BL

- > Allows one-person truck bed removal
- > Four rubber-padded support arms prevent slippage and damage
- > Adjustable center hook allows even weight distribution
- > Durable powder-coat finish
- > Lifetime Warranty
- > Support Arm Adjustment 40" – 73" wide
- > Weight rated to 600 lbs.

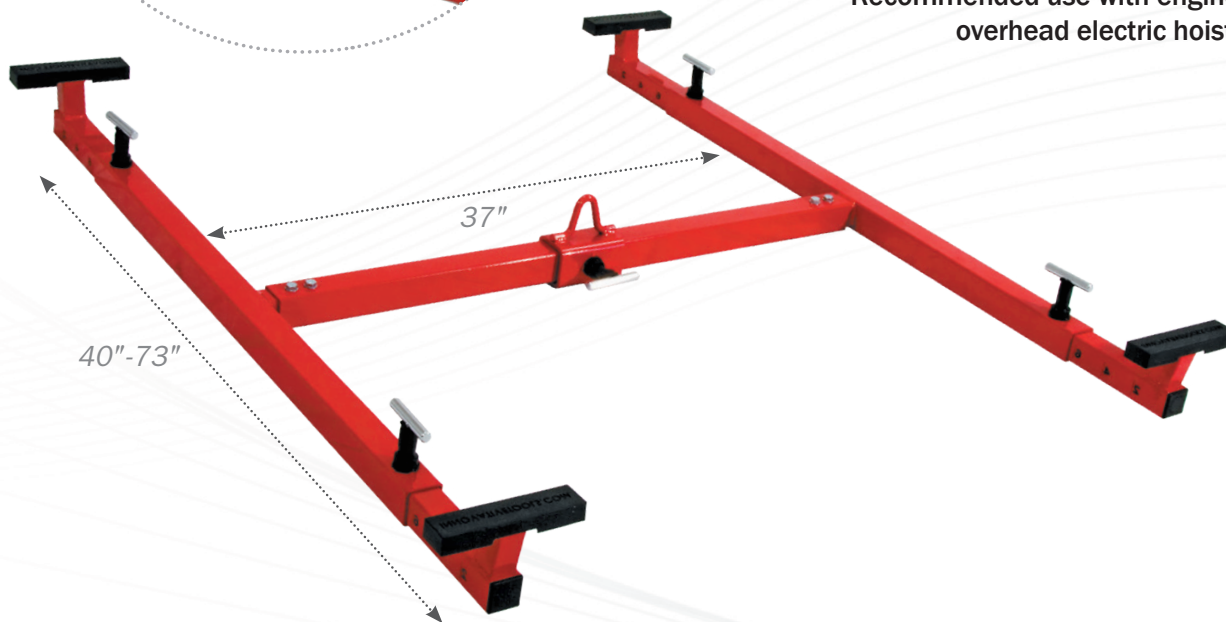

Recommended use with engine hoist or  
overhead electric hoist

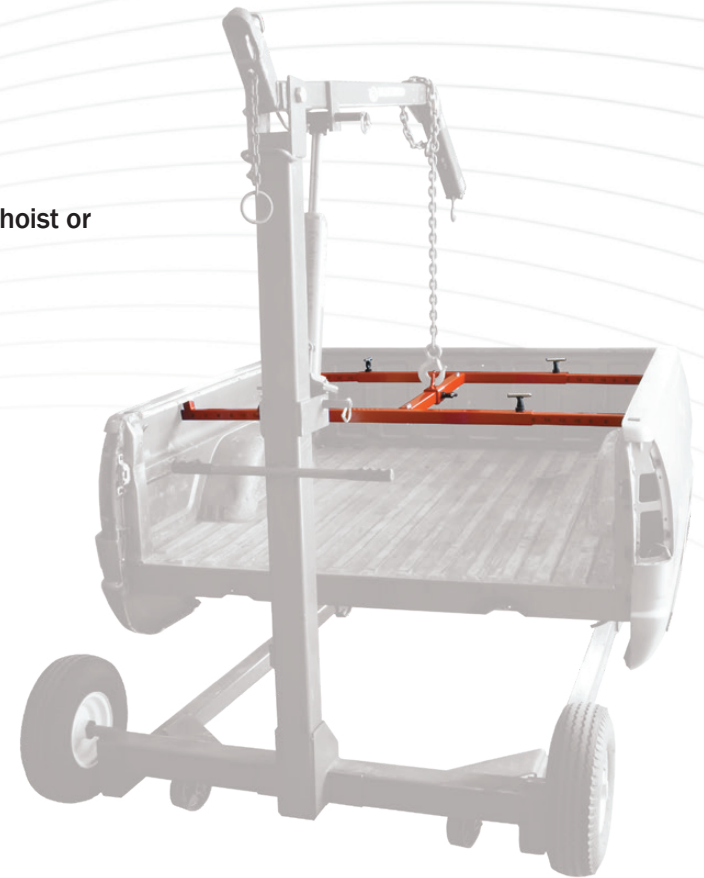

# INNOVATIVE MOBILE MASKER DELUXE

## The Perfect Masker for the Multitasker!



**Innovative  
Mobile Masker Deluxe™**  
*Part # I-MMD*

### < Innovative Mobile Masker Deluxe™ *Part # I-MMD* Patent #10,143,300

- > Holds one roll of up to 12" paper and two rolls of up to 18" paper.
- > Narrow 19" profile makes it easy to maneuver around the shop
- > Thick steel blades allow for longevity while maintaining smooth cutting
- > Easy loading of paper rolls and tape
- > Convenient basket for extra tape, tools and supplies
- > 4" industrial grade, total-lock caster wheels for zero-turn stable mobility; zero movement when locked
- > Holds a roll of 36" paper & a box of plastic sheeting
- > Industry's only 36" stainless steel tear blade for clean, smooth cuts
- > Plastic dispenses from factory box to keep it dust free
- > Nylon bushings for easy material rotation
- > Heavy-duty all steel construction
- > Durable powder-coat finish
- > Measures: 19" W x 33" L x 54" H
- > Lifetime warranty



> Lower cup design allows trouble-free vertical dispensing

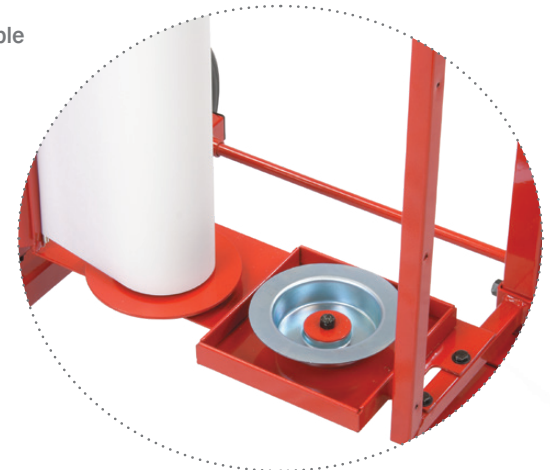

> Industry's only 36" stainless steel tear blade for clean, smooth cuts



> 4" x 1.5" Total-lock wheels provide zero movement with the touch of a toe



# INNOVATIVE MOBILE MASKER

## THE HIGHEST QUALITY MASKERS MADE



### Innovative Mobile Masker™ Part # I-MM

PATENT PENDING

- > Holds one roll of up to 12" paper and two rolls of up to 18" paper.
- > Narrow 19" profile makes it easy to maneuver around the shop
- > Thick steel blades allow for longevity while maintaining smooth cutting
- > Easy loading of paper rolls and tape
- > Convenient basket for extra tape, tools and supplies
- > 4" industrial grade, total-lock caster wheels for zero-turn stable mobility; zero movement when locked
- > Heavy-duty all steel construction
- > Durable powder-coat finish
- > Measures: 19" W x 33" L x 45" H
- > Lifetime warranty



Sharp galvanized steel blade for  
clean cuts every time



Optional Trash Can for Mobile Masker

Part # I-TC

# INNOVATIVE PAPER & PLASTIC DISPENSER



## Innovative Paper & Plastic Dispenser™

Part # I-PPD PATENT #10,143,300

- > Industries only paper & plastic dispenser for vertical & horizontal use
- > Plastic sheeting dispenses from factory box to keep it dust-free
- > Holds a roll of 36" paper & a box of plastic sheeting
- > Nylon bushings for easy material rotation
- > Large 8" wheel for easy mobility
- > Heavy-duty, all steel construction
- > Dispenses all brands of plastic sheeting  
Roll sizes: 12', 16', 20'
- > Durable powder-coat finish
- > Lifetime Warranty
- > 18"W x 23"D x 52"H

> Lower cup design allows trouble-free vertical dispensing

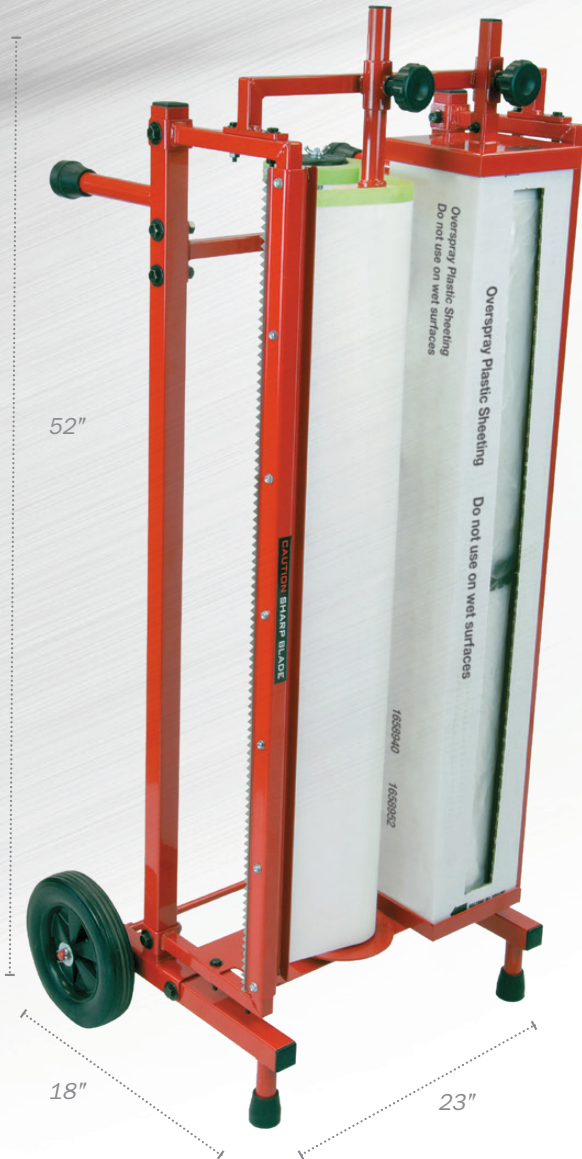

> Industry's only 36" stainless steel tear blade for clean, smooth cuts



> Easily dispense both paper & plastic from the vertical or horizontal position for long, clean paper tears



# INNOVATIVE MOBILE PLASTIC SHEETING DISPENSER



## Innovative Mobile Plastic Sheeting Dispenser™ Part # I-MPSD Patent #10,143,300

- > Keeps your plastic sheeting off of the floor
- > Plastic sheeting dispenses from factory box to keep it dust-free
- > Easily dispense from the vertical or horizontal position
- > Upper & lower cup design allows trouble-free vertical dispensing
- > Nylon bushings for easy material rotation
- > Large 8" wheel for easy mobility
- > Dispenses all brands of plastic sheeting – sizes 12'-16'-20'
- > Durable powder-coat finish
- > Lifetime Warranty

> Upper & lower cup design allows trouble-free vertical dispensing

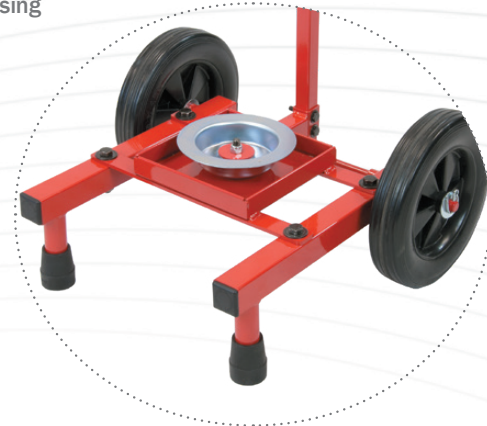

> Solid core 8" wheel

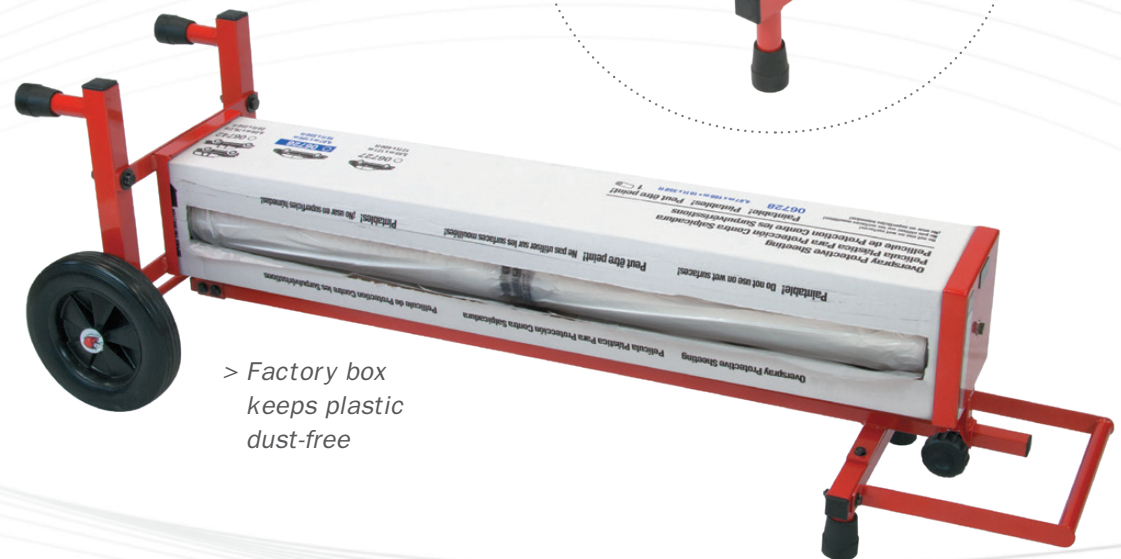
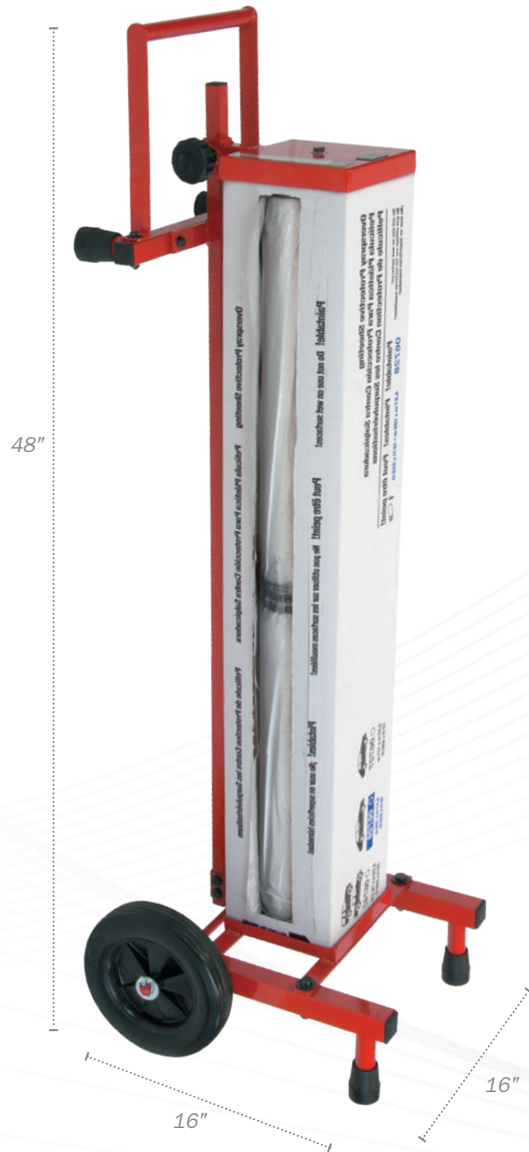

> Factory box keeps plastic dust-free



# EXPERIENCE THE X-FACTOR SO MUCH MORE THAN YOUR AVERAGE SCISSOR STAND!

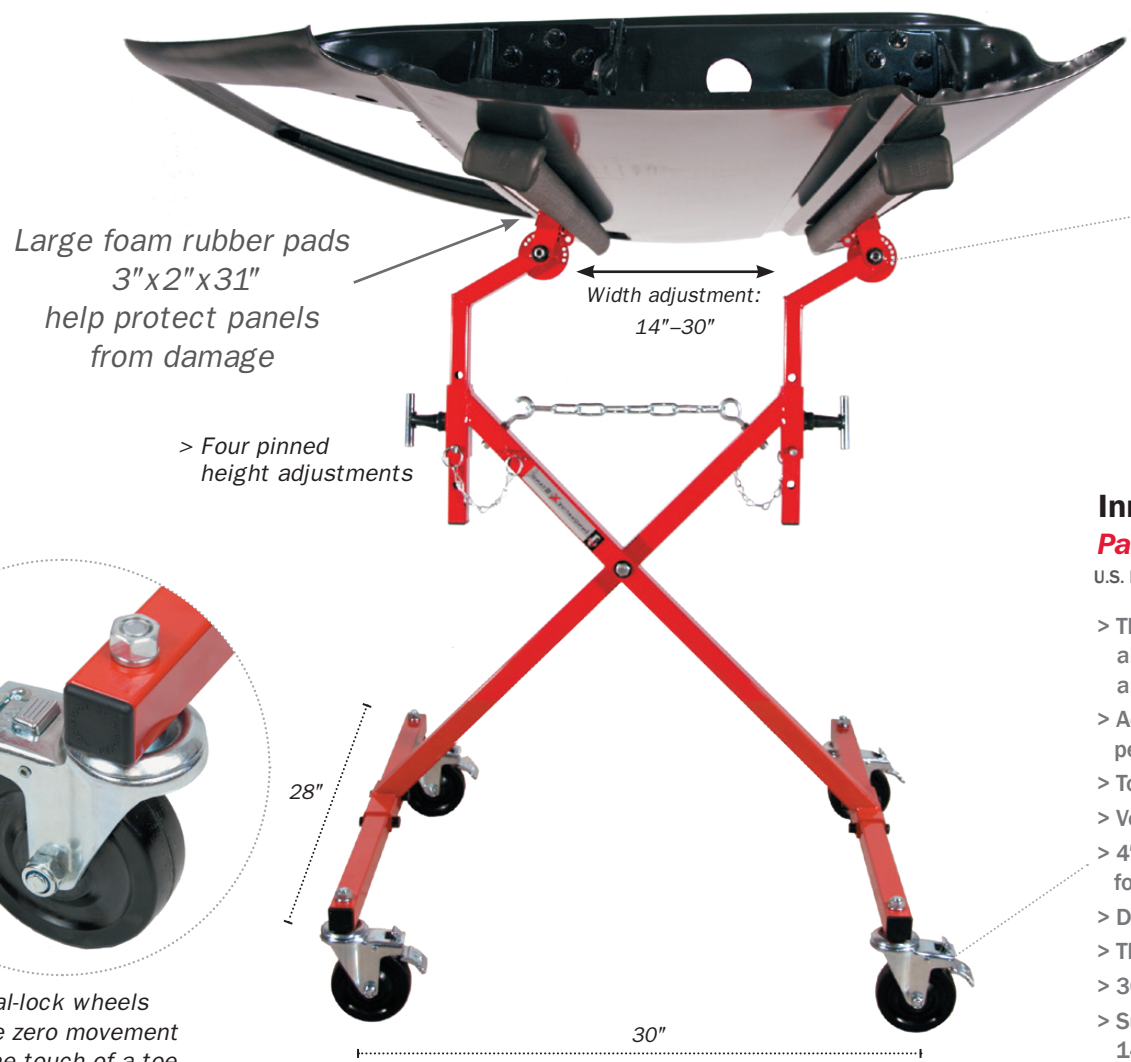

Large foam rubber pads  
3"x2"x31"  
help protect panels  
from damage

Width adjustment:  
14"-30"

> Four pinned  
height adjustments

28"

30"



> Twelve locking  
positions

> Padded support arms  
adjust and lock to  
panel's contours



> 4" Total-lock wheels  
provide zero movement  
with the touch of a toe

## Innovative X-Stand™

**Part # I-XS**

U.S. PATENT 7,988,137

- > The industry's ONLY scissor stand with vertical adjustability allows a comfortable work level for techs; helps prevent back injury and fatigue
- > Accommodates panels of various widths and sizes, perfect for door skin replacement
- > Total flexibility; fits any repair, paint or storage job – including glass
- > Vertical and horizontal adjustability
- > 4" industrial grade, total lock caster wheels for stable mobility; zero movement when locked
- > Durable powder-coat finish
- > Three-Year Warranty
- > 30"W x 28"D x 37"H
- > Support arms adjustment:  
14"W – 30"W & 37"H – 44"H
- > Weight Rating 125 lbs.



# THE PERFECT OPTION!

EVER NEED AN EXTRA HAND?  
HOW ABOUT TWO!

NEW

Hold large bumper covers during the repair process or parts transfer

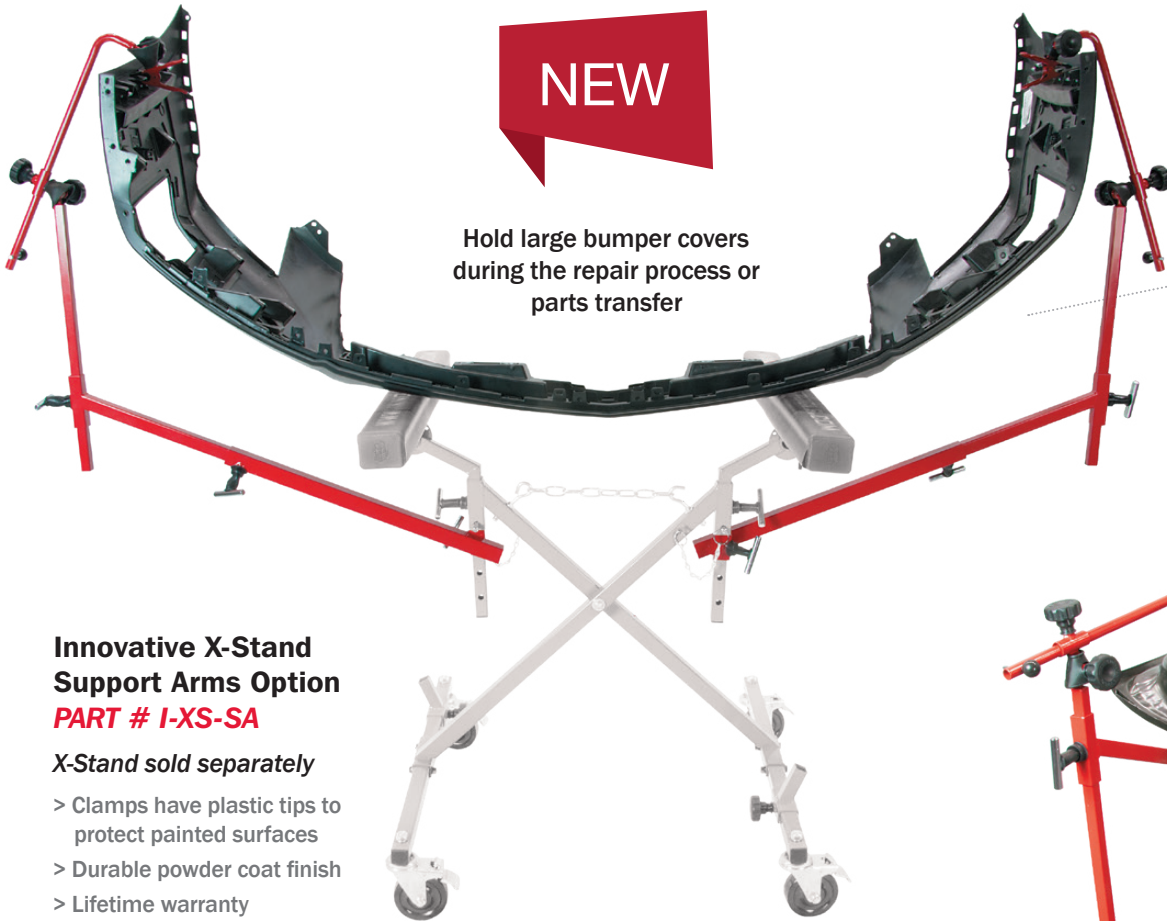

## Innovative X-Stand Support Arms Option **PART # I-XS-SA**

*X-Stand sold separately*

- > Clamps have plastic tips to protect painted surfaces
- > Durable powder coat finish
- > Lifetime warranty



Optional  
Support Arms  
conveniently  
store out of  
the way on the  
X-Stand



Securely holds the  
door during door skin  
replacement

For usage video of the X-Stand and  
optional support arms, visit  
**InnovativeTools.com**

# WALL STORAGE

MAKE USE OF  
VALUABLE WALL SPACE

*X-Stand shown folded  
for compact storage*

**NEW**



## **Innovative X-Stand Pad Covers™**

**PART # I-XS-PC**  
Includes 10 pairs

Pad Covers are ideal for  
protecting painted and  
delicate parts



## **Innovative Wall SuperStorage™** **Part # SSPC-W**

U.S. PATENT 7,314,143

*The benefits of the Parts Cart, without the wheels*

- > Puts small places to work with zero footprint
- > Patented, High-carbon, heat-treated steel shelf brackets for years of trouble-free use
- > 16 square feet of shelving
- > Durable powder-coat finish stays new-looking longer
- > Shelves measure 40"W x 24"D
- > Shelves adjust every 3"
- > Weight rated to 125 lbs. per shelf
- > Includes: 3 adjustable shelves, wall brackets & mounting hardware
- > Lifetime warranty